



**ODISHA POWER TRANSMISSION CORPORATION LTD**  
**CENTRAL PROCUREMENT CELL,**  
**JANPATH, BHUBANESWAR - 751022**  
**TENDER SPECIFICATION NO.**  
**SR.G.M.-CPC-E-TENDER-BATTERY CHARGER-29/2024-25**  
**FOR PROCUREMENT OF BATTERY CHARGERS**

LOT	Description	Requirement
		Total
I	Battery Charger (Thyristor Control) with Dropper Diode suitable for 220 V, 350 AH Vented Lead storage battery(Plante Type) with mandatory spares.	19 set

**PART-I            COMMERCIALBID**

<b>SECTION-I</b>	<b>INSTRUCTION TO TENDERERS</b>
<b>SECTION-II</b>	<b>GENERAL CONDITIONS OF CONTRACT</b>
<b>SECTION-III</b>	<b>LIST OF ANNEXURES</b>
<b>SECTION-IV</b>	<b>TECHNICAL SPECIFICATION</b>

**PART-II            PRICEBID**

<b>Request for online tender documents</b>	<b>From</b>	<b>Date</b>	<b>17.03.2025</b>	<b>To</b>	<b>Date</b>	<b>07.04.2025</b>
		<b>Time</b>	<b>11.00Hrs</b>		<b>Time</b>	<b>12:45Hrs</b>
<b>Pre bid Meeting</b>					<b>Date</b>	<b>24.03.2025</b>
					<b>Time</b>	<b>11.30Hrs</b>
<b>Last date of submission of online tender</b>					<b>Date</b>	<b>07.04.2025</b>
					<b>Time</b>	<b>13:00Hrs</b>
<b>Date of opening of Tender</b>					<b>Date</b>	<b>08.04.2025</b>
					<b>Time</b>	<b>11.00Hrs</b>

**ODISHA POWER TRANSMISSION CORPORATION LTD.  
REGD. OFFICE: JANPATH, BHUBANESWAR – 751 022,  
ODISHA**

***e-TENDER NOTICE NO. CPC- 29/2024-25***

For and on behalf of ODISHA POWER TRANSMISSION CORPORATION LTD, Sr.G.M. [C.P.C.] invites Tenders from reputed manufacturers in two part bidding system for supply of **Battery Chargers**. The interested bidders would be required to enroll themselves on the tender portal [www.tenderwizard.com/OPTCL](http://www.tenderwizard.com/OPTCL). Complete set of bidding documents are available at [www.tenderwizard.com/OPTCL](http://www.tenderwizard.com/OPTCL) from **17.03.2025(13.00Hr)** to **07.04.2025(13.00Hr)**. Interested manufacturers may visit OPTCL's official web site <http://www.optcl.co.in> and [www.tenderwizard.com/OPTCL](http://www.tenderwizard.com/OPTCL) for detail specification.

**N.B: All subsequent addendum / corrigendum to the tender shall be hosted in the OPTCL's official website <http://www.optcl.co.in>, [www.tenderwizard.com/OPTCL](http://www.tenderwizard.com/OPTCL) only.**

**SENIOR GENERAL MANAGER [C.P.C.]**

**NOTICE INVITING TENDER**  
**ODISHA POWER TRANSMISSION CORPORATION LTD.,**  
**REGD. OFFICE: JANPATH, Bhubaneswar.**  
**e-TENDER NOTICE NO.CPC-29/2024-25**

*For and on behalf of the ODISHA POWER TRANSMISSION CORPORATION LTD., the undersigned invites bids under two-part bidding system in e-tendering mode only as per the following details.*

Tender Specification No.	Description of equipment/materials	Quantity In Nos.	Earnest Money Deposit (INRs.)	Cost of Tender Document (In Rs.)	Tender Processing Fee (In Rs.)	Last date of receipt & opening of tender
<b>SR.G.M.- CPC-E- TENDER- BATTERY CHARGER- 29/2024- 25</b>	Battery Charger (Thyristor control) suitable 220V, 350 AH, Vented Lead Acid Storage Battery	19	<b>89,769/-</b> (Rupees Eighty Nine Thousand Seven Hundred Sixty Nine)Only.	<b>Rs.12,000/- +Rs.2,160/- @18% GST) =Rs.14,160/-</b> (Rupees Fourteen thousand one hundred sixty only)	Rs 5,000/ + GST@18 % = Rs 5,900/- (Rupees Five Thousand Nine Hundred only)	<b>07.04.2025 (13.00Hr)</b>  <b>&amp; 08.04.2025 (11.00Hr)</b>

The bidders can view the tender documents from website free of cost.

**TENDER COST:**

The bidders who want to submit bids shall have to pay non-refundable amount 14,160/- only including GST @ 18%) towards the tender cost, online through e-payment gateway link provided in e-tender portal (by using Net Banking, Debit Card or Credit Card). The online payment can be made prior to last date & time of submission of online tender. They have to also submit notarized hard copy of GST registration certificate on or before the scheduled date & time of opening of techno-commercial bid. They have to also submit notarized hard copy of GST registration certificate on or before the date & time of submission of techno-commercial bid.

**TENDER PROCESSING FEE:**

The bidders shall have to submit non-refundable amount of Rs.5,900/- (Rupees Five thousand & nine hundred) only including GST @ 18%) towards the tender processing fee to K.S.E.D.C.Ltd, in e-payment mode. The e-payment of above amount is to be made to enable the bidder to down load the bid proposal sheets & bid document in electronic mode.

**SUBMISSION OF TENDER COST, TENDER PROCESSING FEE & EMD:**

The bidder shall deposit the tender cost, tender processing fee & EMD BG prior to last date & time for submission of bid as notified in tender notice. Local micro & small enterprisers

(MSEs) **(In the state of Odisha)** based in Odisha and registered with respective DICs, Khadi, Village, Cottage & Handicrafts Industries, OSIC and NSIC can participate **by submitting EMD @ 50(fifty) percent(%) of the amount indicated in the Notice Inviting Tender**. They have to submit notarized hard copy of valid registration as local MSE **(In the state of Odisha)** as above on or before the date & time of submission of techno-commercial bid.

**The tender cost , processing fees are to be submitted along with the EMD at the office of the undersigned on or before the last date & time of submission of tender.**

The bidders shall scan the Demand Draft/Pay order/ Bank guarantee, towards EMD/ notarised hard copy of valid registration as local MSE **(In the state of Odisha)** (if any) and upload the same in the prescribed form in .gif or .jpg format in addition to sending the original as stated above.

The prospective bidders are advised to register their user ID, Password, company ID from website **www.tenderwizard.com/OPTCL** by clicking on hyper link “Register Me”.

Any clarifications regarding the scope of work and technical features of the tender can be had from the undersigned during office hours.

***Minimum qualification criteria of bidders: AS STIPULATED IN SECTION-II, (G.T.C.C) OF THE TENDER SPECIFICATION.***

**SENIOR GENERAL MANAGER,CPC**

**ODISHA POWER TRANSMISSION CORPORATION LTD.**

**OFFICE OF THE SR. GENERAL MANAGER**

**CENTRAL PROCUREMENT CELL**

**FAX NO.:0674 – 2542964**

**TELEPHONE NO.:0674 – 2541801**

**JANAPATH, BHUBANESWAR – 751022**

**TENDER SPECIFICATION NO.**

**SR.G.M.-CPC-E- TENDER-BATTERY CHARGER-29/2024-25**

**CONTAINING**

**PART – I**

**SECTION – I : INSTRUCTION TO TENDERERS**

**SECTION – II : GENERAL TERMS AND CONDITIONS OF  
CONTRACT ( G.T.C.C.)**

**SECTION – III : LIST OF ANNEXURES**

**SECTION – IV : TECHNICAL SPECIFICATION**

**PART – II PRICE BID.**

**PART – I.**  
**SECTION – I.**

**INSTRUCTIONS TO TENDERERS**

<b><u>Clause.</u></b>	<b><u>Title.</u></b>	<b><u>Page.</u></b>
1.	Submission of Bids.	07
2.	Division of Specification.	08
3.	Tenders shall be in two parts.	09
4.	Opening of Bids.	09
5.	Purchaser's right regarding alteration in Quantities, Tendered.	10
6.	Procedure and opening time of tenders.	10
7.	Bidder's liberty to deviate from specification.	10
8.	Eligibility for submission of bids.	10
9.	Purchaser's right to accept/reject bids.	10
10.	Mode of submission of tenders.	11
11.	<b>Earnest money deposit.</b>	11
12.	Validity of the bids.	12
13.	Price.	12
14.	Revision of Tender Price by Bidders.	12
15.	Tenderers to be fully conversant with the clauses of the Specification.	12
16.	Documents to accompany Bids.	12
17.	Documents/Papers to Accompany PART – II Bid.	13
18.	Conditional Offer.	13
19.	General.	13
20.	Expenses in respect of OPTCL's representative for witnessing the inspection & testing of the offered equipment/materials at the inspection and testing site.	14
21.	Litigation/Arbitration	16

## COMMERCIAL SPECIFICATION.

### PART-I

#### SECTION-I

#### INSTRUCTIONS TO TENDERER

##### 1. Submission of Bids: -

The bidder shall submit the bid in Electronic Mode only i.e. [www.tenderwizard.com/OPTCL](http://www.tenderwizard.com/OPTCL). The bidder must ensure that the bids are received in the specified website of the OPTCL by the date and time indicated in the Tender notice. Bids submitted by telex/telegram will not be accepted. No request from any bidder to the OPTCL to collect the Bids in physical form will be entertained by the OPTCL.

The OPTCL reserves the right to reject any bid, which is not deposited according to the instruction, stipulated above. The participants to the tender should be registered under GST laws.

1. For all the users it is mandatory to procure the Digital Signatures.
2. Contractors / Vendors / Bidders / Suppliers are requested to follow the below steps for **Registration**:
  - a. Click “Register”, fill the online registration form.
  - b. Pay the amount of **Rs. 2360/-** through e-payment/DD in favour of  
K S E D C Ltd Payable at Bangalore.
  - c. Send the acknowledgment copy for verification.
  - d. As soon as the verification is being done the e-tender user id will be enabled.
3. After viewing Tender Notification, if bidder intends to participate in tender, he has to use his e-tendering User Id and Password which has been received after registration and acquisition of DSCs.
4. If any Bidder wants to participate in the tender he will have to follow the instructions given below:
  - a. Insert the PKI (which consist of your Digital Signature Certificate) in your System.  
(Note: Make sure that necessary software of PKI be installed in your system).
  - b. Click / Double Click to open the Microsoft Internet Explorer (This icon will be located on the Desktop of the computer).
  - c. Go to Start > Programs > Internet Explorer.
  - d. Type **www.tenderwizard.com/OPTCL** in the address bar, to access the Login Screen.
  - e. Enter e-tender User Id and Password, click on “Go”.

- f. Click on “Click here to login” for selecting the Digital Signature Certificate.
  - g. Select the Certificate and enter DSC Password.
  - h. Re-enter the e-Procurement User Id Password
5. To make a request for Tender Document Bidders will have to follow below mentioned steps.
    - Click “Un Applied” to view / apply for new tenders.
    - Click on Request icon for online request.
  6. After making the request Bidders will receive the Tender Documents which can be checked and downloaded by following the below steps:
    - Click to view the tender documents which are received by the user.
    - Tender document screen appears.
    - Click “Click here to download” to download the documents.
  7. After completing all the formalities Bidders will have to submit the tender and they must take care of following instructions.
    - Prior to submission, verify whether all the required documents have been attached and uploaded to the particular tender or not.
    - Note down / take a print of bid control number once it displayed on the screen
  8. Tender Opening event can be viewed online.
  9. Competitors bid sheets are available in the website for all.
  10. **For any e-tendering assistant contact help desk number mentioned below.**
    - Bangalore – 080- 40482000.

The participants to the tender should be registered under GST laws.

## **2. Division of Specification.**

The specification is mainly divided into two parts viz. Part-I & Part-II.

### **Part-I Consists of**

- |                   |   |
|-------------------|---|
| [i] Section-I     | Instruction to Tenderers.               |
| [ii] Section-II   | General Terms & conditions of contract. |
| [iii] Section-III | Schedules and forms etc.                |
| [iv] Section-IV   | Technical Specification.                |



## **Part-II Consists of**

Schedule of prices as per Annexure-V

### **3. Tenders shall be in Two Parts.**

The Tenderers are required to submit the tenders in two parts viz. Part-I ( Techno commercial) & Part-II (Price bid).

### **4. Opening of Bids.**

[a] The part-I shall be opened on the date and time fixed by the OPTCL for opening of bids in Electronic mode in presence of such of the Tenderers or their authorized representatives [limited to one person only] on the due date of opening of tender who opt remain present. After scrutiny of the technical particulars and other commercial terms, clarifications, if required, shall be sought for from the bidders. The Tenderers shall be allowed 15 days' time for such activity.

[b] On receipt of technical clarification, the bids shall be reviewed, evaluated and those not in conformity with the technical Specification / qualifying experience, shall be rejected. If any of the technical proposal requires modification to make them comparable, discussion will be held with the participating bidders.

All the responsive bidders shall be given opportunity to submit the revised technical and revised price proposals as a follow up to the clarification (modification if any) on the technical proposals. The qualified bidders shall be given opportunity to submit revised price proposals within 15 days from the date of such discussion or within time frame mutually agreed, whichever is earlier.

[c] When the revised price proposals are received, the original price proposals will be returned to the bidders unopened along with their original technical proposals. Only the revised technical and price proposals will be considered for bid evaluation. The price bids [Part-II] of such of the Tenderers, whose tenders have been found to be technically and commercially acceptable, including those supplementary revised price bids, submitted subsequently, shall be opened in the presence of the bidder's representative on a date and time which will be intimated to all technically and commercially acceptable Tenderers.

[d] The bidders are required to furnish sufficient information to the Purchaser to establish their qualification, capacity to manufacture and/or supply the materials/perform the work. Such information shall include details of bidder's experience, its financial, managerial and technical capabilities.

[e] The bidders are also required to furnish details of availability of appropriate technical staff and capability to perform after sales services. The above information

shall be considered during scrutiny and evaluation of bids and any bid which does not satisfactorily meet these requirements, shall not be considered for price bid evaluation.

[f] The price bids of the technically and otherwise acceptable bids shall only be evaluated as per the norms applicable in terms of this Specification.

5. Purchaser's Right Regarding Alteration of Quantities Tendered.

**The Purchaser may alter the quantities of materials/equipment at the time of placing orders. Initially the purchaser may place orders for lesser quantity with full freedom to place extension orders for further quantity under similar terms and conditions of the original orders. Orders may also be split among more than one tenderer for any particular item, if considered necessary in the interest of the Purchaser or to get the goods/equipment earlier.**

6. Procedure and opening time of tenders.

Tenders will be opened in the office of the Senior General Manager [C.P.C.] on the specified date and time in presence of the Tenderers or their authorized representatives [limited to one person only] in case of each bidder who may desire to be present, at the time of opening the bids.

7. Bidder's Liberty to deviate from Specification.

The Tenderer may deviate from the specification while quoting, if in his opinion, such deviation is in line with the manufacturer's standard practice and conducive to a better and more economical offer. All such deviations should however be clearly indicated giving full justifications for such deviation. [Read with Clause-9, Section-II of the Specification].

8. Eligibility for submission of bids.

Only those manufacturers who have deposited the cost of tender specification are eligible to participate in the tender. They should submit the money receipt as a proof of such payment. The local Micro and small Enterprises(MSEs) (In the state of Odisha) registered with respective DICs, Khadi, Village, Cottage & Handicrafts Industries, OSIC and NSIC can participate **without payment of the cost of tender** specification

9. Purchaser's right to accept/reject bids:

The purchaser reserves the right to reject any or all the tenders without assigning any reasons what so ever if it is in the interest of OPTCL, under the existing circumstances. [Read with clause-10, Section-II of the specification].

10. Mode of submission of Tenders.

[A] Tenders shall be submitted in electronic mode only.  
(www.tenderwizard.com/OPTCL)

[B] **Telegraphic or FAX tenders** shall not be accepted under any circumstances.

**11. Earnest money deposit:**

The tender shall be accompanied by Earnest Money deposit of value specified in the notice inviting tenders against each lot / bid. Tenders without the required EMD as indicated at **Annexure-VIII** will be rejected out rightly.

The local Micro and small Enterprises (MSEs) (In the state of Odisha) registered with respective DICs, Khadi, Village, Cottage & Handicrafts Industries, OSIC and NSIC can participate by submitting Earnest Money Deposit @ fifty percent of the amount indicated in the Notice Inviting Tender.

The earnest money deposit shall be furnished in one of the following forms subject to the conditions mentioned below:

- (a) **Bank Draft:** -To be drawn in favour of Drawing & Disbursing Officer, OPTCL [H.Qrs.Office], Bhubaneswar-751 022.
- (b) Bank Guarantee from any Nationalized/Scheduled Bank strictly as per enclosed proforma vide **Annexure-VI** to be executed on non-judicial stamp paper worth Rs.29.00 or as applicable, as per prevailing laws in force and also to be accompanied by the confirmation letter of the issuing Bank Branch.

**NOTE:**

- (i). The validity of the EMD in the form of Bank Guarantee shall be at least for 240 days from the date of opening of tender failing which the tender will be liable for rejection.
- (ii) No interest shall be paid on the Earnest Money Deposit.
- (iii) E.M.D. in shape of cash may be submitted up to Rs. 25,000/- (Rupees Twenty-five Thousand) only. Above Rs. 25,000/- (Rupees Twenty-five thousand) the Earnest Money Deposit shall be furnished in any one of the forms indicated above (i.e. Through Bank Draft, Bank Guarantee/ National Savings Certificate).
- (iv) No adjustment towards EMD shall be permitted against any outstanding amount with the **ODISHA POWER TRANSMISSION CORPORATION LTD.**
- (v) The chart showing particulars of EMD to be furnished by Tenderers of different categories is placed at **Annexure-VIII.**
- (vi) In the case of un- successful tenderer, the EMD will be refunded after the tender is decided. In the case of successful Tenderer, this will be refunded only after furnishing of security money referred to at clause-19 of Section-II.
- (vii) Suits, if any, arising out of this clause shall be filed in a Court of law to which the jurisdiction of High Court of ODISHA extends.

- (vii) EMD will be forfeited if the tenderer fails to accept the letter of intent and/or purchase order issued in his favour or to execute the order, placed on them.
- (viii) Tenders not accompanied by Earnest Money shall be disqualified.

**12. Validity of the Bids: -**

The tenders should be kept valid for a period of **180** days from the date of opening of the tender, failing which the tenders will be rejected.

**13. PRICE: -**

Tenderers are requested to quote-‘FIRM’ Price. No deviation from **FIRM PRICE** will be entertained irrespective of deviation clause No.7 of this part of the specification.

**14. Revision of tender price by Bidders: -**

[a] After opening of tenders and within the validity of period, no reduction or enhancement in price will be entertained. If there is any change in price, the tender shall stand rejected and the EMD deposited shall be forfeited.

[b] After opening of price bid if the validity period is not sufficient to place purchase order, the tenderer may be asked by the purchaser to extend the validity period of the bid under the same terms and condition as per the original tender.

However, the tender are free to change any or all conditions including price except delivery period of their bids at their own risk, if they are asked by the purchaser to extend the validity period of the bid prior to opening of price bid.

**15. Tenderers to be fully conversant with the clauses of the Specification: -**

Tenderers are expected to be fully conversant with the meaning of all the clauses of the specification before submitting their tenders. In case of doubt regarding the meaning of any clause, the tenderer may seek clarification in writing from the Senior General Manager (Central Procurement Cell) OPTCL. This, however, does not entitle the Tenderer to ask for time beyond due date, fixed for receipt of tender.

**16. Documents to Accompany Bids.**

Tenderers are required to submit tenders in the following manner:

**Part-I of the Tender shall Contain the following documents.**

- [i] Declaration Form. [As per Annexure-I]
- [ii] Earnest Money. [As per **Annexure-VIII**], Tender Cost .
- [iii] Technical specification and Guaranteed Technical Particulars conforming to the Purchaser’s Specification along with drawings, literatures and all other required Annexures, duly filled in.
- [iv] Photostat copies of type test certificates of materials/equipments offered as stipulated in the Technical Specification.
- [v] Abstract of Terms & conditions in prescribed proforma as per **Annexure-II**.

- [vi] General Terms & Conditions of supply offer as per Section-II of the Specification.
- [vii] List of orders executed for similar materials/equipments during preceding 2 (two) years indicating the customer's name, Purchase Order No. & Date, date of supply and date of commissioning etc.
- [viii] Data on past experience **as per Clause-7 of Section-II** of the Specification.
- [ix] GST Compliance Rating. The GST Identification Number(GSTIN) under GST Laws and permanent account number [PAN] of the firm, **IT return for last 3 years** under Income tax Act are required.
- [x] Audited Balance sheet & profit loss accounts of the bidder, for past (3) three years.
- [xi] Schedule of quantity and delivery in the prescribed Proforma vide Annexure, as appended.
- [xii] List of Orders in hand to be executed.
- [xiii] Deviation schedule.
- [xiv] Notarized hard copy and soft copy of valid registration as local MSE (In the state of Odisha) (if any).
- [xv] The bidder should not have any pending litigation or arbitration with OPTCL with regard to any project or related activity. The bidder should certify/declare the same in unequivocal terms by way of an affidavit duly sworn before a magistrate or a notary.
- [xvi] Reverse Auction Process Compliance Form (Annexure-IB)
- [xvii] Certificate of DPIIT

**17. Documents/Papers to accompany Part-II Bid.**

- (a) Part – II of the tender shall consist of the following  
Schedule of prices in the prescribed proforma as per Annexure-V

**18. Conditional Offer:**

Conditional offer shall not be accepted.

**19. General: -**

- (i) In the event of discrepancy or arithmetical error in the schedule of price, the decision of the purchaser shall be final and binding on the Tenderer.
- (ii) For evaluation, the price mentioned in words shall be taken if there is any difference in figures and words in the price bid.
- (iii) Notice inviting tender shall form part of this specification.
- (iv) The price bids of the technically and otherwise acceptable bids shall only be evaluated. **The EMD of others, if any, shall be returned to the bidders.**
- (v) Tenderer can offer any lot or all the lots of the tender, if there are more than one lot. But the tender (bid) must be furnished separately for each lot. For each lot, the tenderer has to submit PART-I & PART-II of the bids separately.

- (vi) It should be distinctly understood that the part-II of the bid shall contain only details/documents relating to price, as outlined in clause-17 mentioned herein above. Inclusion of any of the documents/information etc. shall render the bid liable for rejection.
- (vii) The tenderer must submit the EMD amount, cost of tender document (Form Fee) and Tender processing fee in a sealed cover envelope super-scribing the tender specification number, Tender Notice No & Date of tender clearly on the cover envelope. The said envelope is to be submitted in the office of the purchaser on or before the last date and time of submission of Bids.

**20.0 Expenses in respect of OPTCL's representative for witnessing the inspection & testing of the offered equipment/materials at the inspection and testing site.**

The testing and inspection of the equipment/ materials at manufacturer works are in the scope of work of the Contractor/Supplier.

OPTCL inspecting officer, on receipt of offer for inspection from the contractor/supplier, proceeds to the manufacturer works to witness the Type/Acceptance/Routine test.

**Important:**

It is hereby informed to all the bidders that the relevant clauses of the contract specification, pertaining to inspection and testing of equipment/materials, are hereby supplemented with following additional terms and conditions.

*The expenses under the following heads, in respect of OPTCL's representative for witnessing the inspection & testing of the offered equipment/materials at the inspection and testing site, shall be borne by the contractor / supplier.*

**a) Hotel Accommodation:**

*I. Single room accommodation in 4 star hotel for the OPTCL inspecting officer of the rank of Assistant General Manager (Grade E-6) and above.*

*II. Single room accommodation in 3 star hotel for the OPTCL inspecting officer of the rank below Assistant General Manager (Grade E-6).*

**N.B.:** *It is the responsibility of the contractor to arrange the hotel accommodation matching with their inspection and testing schedule, so that the inspecting officer can check-in the hotel one day prior to the date of inspection and check out after the completion of the inspection, subject to availability of the return travel ticket. In case of extended duration of inspection or non-availability of the return travel ticket, Contractor/supplier/manufacturer shall arrange for the extended stay of the inspecting officer in the Hotel accordingly. In case*

there is no hotel with prescribed standard in and around the place of inspection, the contractor/supplier/manufacturer shall suggest alternative suitable arrangement at the time of offer for inspection, which is subjected to acceptability of OPTCL inspecting officer.

**b) Journey of the inspecting officer:**

(i) To and fro travel expenditure from the Head Quarters of the inspecting officer to the place of inspection/testing shall be borne by the contractor/supplier/manufacturer. Journey from the Head Quarters of the inspecting officer to the nearest Air Port by train (Ist/IIInd A.C) & A/C Taxi then by Air to the place of inspection/testing or to the nearest place of inspection/testing and then by train (Ist/IIInd A.C) & A/C taxi to the place of inspection/testing shall be arranged by the contractor/supplier/manufacturer.

(ii) For train journey, inspecting officer of the rank Assistant General Manager and above shall be provided with 1st class AC ticket and inspecting officer below the rank of Assistant General Manager shall be provided with 2nd class AC ticket.

(iii) The Air-ticket / train-ticket booking/cancellation is the responsibility of the contractor / supplier.

(iv) Moreover, if during the journey there is an unavoidable necessity for intermediate travel by road/ waterway/sea-route, the contractor/supplier shall provide suitable conveyance to the inspecting officer for travel this stretch of journey or bear the cost towards this. Any such possibilities shall be duly intimated to OPTCL at the time of their offer for inspection.

**c) Local Conveyance:**

At the place of the inspection/testing, for local journey of the inspecting officer between Hotel and inspection/testing site and or any other places, Air-conditioned four wheeler vehicle in good condition shall be provided by the contractor/supplier/manufacturer.

**d) Following points are also to be considered:**

(i) All the above expenses shall be deemed to be included in the bidder's quoted price for that supply item. Bidder shall not be eligible to raise any extra claim in this regard.

(ii) Contractor/supplier/manufacturer may assume that only in 40% of the inspection and testing offer cases, OPTCL inspecting officer, not below the rank of Assistant General Manager will witness the inspection and testing.

(iii) In case of inspection and testing of some critical equipment/materials like Power transformers, OPTCL may depute more than one inspecting officer.

(iv) Contractor/supplier/manufacturer shall judiciously plan the inspection/testing schedule and place of inspection/testing, so that optimum number of inspection/testing and minimum time shall be required to cover all the equipment/materials of the relevant contract package.

(v) It shall be the responsibility of the Contractor/Supplier to organize the above tour related matters of OPTCL inspecting officer including the matters related to overseas inspection/testing, if any.

**21. Litigation/Arbitration**

**(i)**- Bidder has to furnish detailed information on any litigation or arbitration arising out of contracts completed or under execution by it over the last five years. A consistent history of litigation by or against the bidder may result in rejection of bid.

**(ii)** The bidder should not have any pending litigation or arbitration with OPTCL with regard to any project or related activity. The bidder should certify/declare the same in unequivocal terms by way of an affidavit duly sworn before a magistrate or a notary. Bid furnished by the bidder shall not be eligible for consideration if it is not accompanied by the affidavit. Further, the bid/LOA/LOI shall liable for outright rejection/cancellation at any stage if any information contrary to the affidavit/declaration is detected.



**SECTION – II.**  
**GENERAL TERMS AND CONDITIONS OF CONTRACT [G.T.C.C.]**

<b><u>Clause.</u></b>	<b><u>Title.</u></b>	<b><u>Page.</u></b>
1.	Scope of the contract.	18
2.	Definition of terms.	18
3.	Manner of execution.	19
4.	Inspection and testing.	19
5.	Training facilities.	20
6.	Rejection of materials.	20
7.	Experience of bidders.	21
8.	Language and measures.	21
9.	Deviation from Specification.	21
10.	Right to reject/accept any tender.	22
11,	Supplier to inform himself fully.	22
12.	Patent rights etc.	22
13.	Delivery.	22
14.	Despatch Instructions.	23
15.	Supplier's Default Liability.	23
16	Force Majeure.	23
17.	Extension of Time.	24
18.	Guarantee Period.	24
19.	Bank Guarantee towards Security Deposit, Payment and Performance.	24
20.	Import License.	25
21.	Terms of Payment.	25
22.	Penalty for Delay in Completion of Contract.	26
23.	Insurance.	27
24.	Payment Due from the Supplier.	27
25.	Sales Tax clearance, Balance Sheet& P/L A/C	27
26.	Certificate of exemption from E.D/Sales Tax.	27
27.	Supplier's Responsibility.	27
28.	Validity.	27
29.	Evaluation.	27
30.	Minimum qualification criteria of Bidders.	31
31.	Jurisdiction of High Court of ODISHA.	32
32.	Correspondences.	32
33.	Official Address of the Parties to the Contract.	32
34.	Outright rejection of Tenders.	32
35.	Documents to be treated as confidential.	34
36.	Scheme/Projects.	34

**PART-I**  
**SECTION-II**

**GENERAL TERMS AND CONDITIONS OF CONTRACT [G.T.C.C.]**

**1. Scope of the contract:**

The scope of the contract shall be to design, manufacture, supply of equipment as per the specification at the consignee's site, and rendering services in accordance with the enclosed technical specification and bill of quantity.

**2.0 Definition of terms:**

For the purpose of this specification and General Terms and Conditions of contract [GTCC], the following words shall have the meanings hereby indicated, except where otherwise described or defined.

- 2.1 "The Purchaser" shall mean the Senior General Manager[Central Procurement Cell] for and on behalf of ORISSA POWER TRANSMISSION CORPORATION LTD., Bhubaneswar.
- 2.2 "The Engineer" shall mean the Engineer appointed by the Purchaser for the purpose of this contract.
- 2.3 "Purchaser's Representative" shall mean any person or persons or consulting firm appointed and remunerated by the Purchaser to supervise, inspect, test and examine workmanship and materials of the equipment to be supplied.
- 2.4 "The supplier" shall mean the bidder whose bid has been accepted by the purchaser and shall include the bidder's executives, administrators, successors and permitted assignees.
- 2.5 "Equipment" shall mean and include all machinery, apparatus, materials, and articles to be provided under the contract by the suppliers.
- 2.6 "Contract Price" shall mean the sum named in or calculated the bid.
- 2.7 "General Condition" shall mean these General Terms and Conditions of Contract.
- 2.8 "The Specification" shall mean both the technical as well as commercial parts of the specification annexed to or issued with GTCC and shall include the schedules and drawings, attached thereto as well as all samples and pattern, if any.
- 2.9 "Month" shall mean "Calendar month".
- 2.10 "Writing" shall include any manuscript, type written, printed or other statement reproduction in any visible form and whether under seal or under hand.
- 2.11 "Basic Price (Taxable value for Goods) at the point of destination" shall mean the price quoted by the bidder for equipment and material at the consignee's store/site. The cost is inclusive of packing, forwarding, freight, insurance and all expenses and taxes & duties at the end of the supplier excluding Goods & Service Tax. The Goods & Service Tax shall be shown in a separate column item wise alongside the Basic

Price quoted at the applicable rate in the Tax Invoice. The applicable rate of GST shall refer to the HSN code of the material supplied. The Basic Price and GST thereon shall be the “FOR Destination Price” as quoted by the bidder.

2.12 The term “Contract document” shall mean and include GTCC, specifications, schedules, drawings, form of tender, Notice Inviting Tender, covering letter, schedule of prices or the final General Conditions, any special conditions, applicable to the particular contract.

2.13 Terms and conditions not herein defined shall have the same meaning as are assigned to them in the Indian Contract Act, failing that in the Orissa General Clauses Act.

**3. Manner of execution:**

All equipment supplied under the contract shall be manufactured in the manner, set out in the specification or where not set out, to the reasonable satisfaction of the Purchaser’s representative.

**4. Inspection and Testing:**

[i] The purchaser’s representative shall be entitled at all reasonable times during manufacture to inspect, examine and test at the supplier’s premises, the materials and workmanship of all equipment/materials to be supplied under this contract and if part of the said equipment/material is being manufactured in other premises, the supplier shall obtain for the purchaser’s representative permission to inspect, examine and test as if the equipment/material were being manufactured in the contractor’s premises. Such inspection, examination and testing shall not relieve the supplier from his obligations under the contract.

[ii] The Supplier shall give to the purchaser adequate time/notice (at least clear 15 days for inside the state suppliers and 20 days for outside the state suppliers) in writing for inspection of materials indicating the place at which the equipment/material is ready for testing and inspection and shall also furnish the shop Routine Test Certificate, Calibration certificates of Testing instruments, calibrated in Govt. approved laboratory with authenticity letter of that laboratory along with the offer for inspection. A packing list along with the offer, indicating the quantity which can be delivered in full truck load/Mini truck load to facilitate issue of dispatch instruction shall also be furnished.

[iii] Where the contract provides for test at the Premises of the supplier or any of his sub-vendors, the supplier shall provide such assistance, labour, materials, electricity, fuel and instruments, as may be required or as may be reasonably demanded by the Purchaser’s representative to carryout such tests efficiently. The supplier is required to produce shop routine test Certificate, calibration certificates

of Testing Instruments before offering their materials/equipment for inspection & testing. The test house/laboratory where tests are to be carried out must be approved by the Govt. A letter pertaining to Govt. approved laboratory must be furnished to the purchaser along with the offer for inspection.

- [iv] After completion of the tests, the Purchaser's representative shall forward the test results to the Purchaser. If the test results conform to the specific standard and specification, the Purchaser shall approve the test results and communicate the same to the supplier in writing. The supplier shall provide at least five copies of the test certificates to the Purchaser.
- [v] The Purchaser has the right to have the tests carried out at his own cost by an independent agency whenever there is dispute regarding the quality of supply.
- [vi] If the firm fails to present the offered items for inspection/testing as per their inspection call due to any reason(s) during the visit of inspecting officer at the testing site, the firm shall have to bear all expenses towards repetition of inspection and testing of the total offered quantity or part thereof.

**5. Training facilities.**

The supplier shall provide all possible facilities for training of Purchaser's Technical personnel, when deputed by the Purchaser for acquiring first hand knowledge in assembly of the equipment, its erection, commissioning and for its proper operation & maintenance in service, wherein it is thought necessary by the purchaser.

**6. Rejection of Materials.**

In the event any of the equipments/material supplied by the manufacturer is found defective due to faulty design, bad workmanship, bad materials used or otherwise not in conformity with the requirements of the Specification, the Purchaser shall either reject the equipment/material or ask the supplier in writing to rectify or replace the defective equipment/material free of cost to the purchaser. The Supplier on receipt of such notification shall either rectify or replace the defective equipment/material free of cost to the purchaser within 15 days from the date of issue of such notification by the purchaser. If the supplier fails to do so, the Purchaser may:-

- [a] At its option replace or rectify such defective equipment/materials and recover the extra costs so involved from the supplier plus fifteen percent and/or.
- [b] Terminate the contract for balance work/supplies, with enforcement of penalty Clause as per contract for the un-delivered goods and with forfeiture of Performance Guarantee/ Composite Bank guarantee.
- [c] Acquire the defective equipment/materials at reduced price, considered equitable under the circumstances.

**7. Experience of Bidders:**

The bidders should furnish information regarding experience particularly on the following points:

- [i] Name of the manufacturer:
- [ii] Standing of the firm and experience in manufacture of equipment/material quoted:
- [iii] Description of equipment/material similar to that quoted, supplied and installed during the last two years with the name(s) of the Organisations to whom supplies were made wherein, at least one (1) certificate shall be from a state/central P.S.U.
- [iv] Details as to where installed etc.
- [v] Testing facilities at manufacturer's works.
- [vi] If the manufacturer is having collaboration with another firm [s], details regarding the same.
- [vii] A list of purchase orders of identical material/equipment offered as per technical specification executed during the last two years along with users certificate. User's certificate shall be legible and must indicate, user's name, address, designation, place of use, and satisfactory performance of the equipment/materials for at least two years from the date of commissioning. Wherein at least one (1) certificate shall be from a State/Central or P.S.U. Bids will not be considered if the past manufacturing experience is found to be un-satisfactory or is of less than 2 (two) years on the date of opening of the bid and bids not accompanying user's certificate will be rejected..

**8. Language and measures:**

All documents pertaining to the contract including specifications, schedule, notices, correspondence, operating and maintenance instructions., drawings or any other writing shall be written in English language. The metric system of measurement shall be used exclusively in this contract.

**9. Deviation from specification:**

It is in the interest of the tenderers to study the specification, specified in the tender schedule thoroughly before tendering so that, if any deviations are made by the Tenderers,(both commercial and Technical), the same are prominently brought out on a separate sheet under heading "Deviations Commercial" and "Deviations Technical".

A list of deviations shall be enclosed with the tender. Unless deviations in scope, technical and commercial stipulations are specifically mentioned in the list of deviations, it

shall be presumed that the tenderer has accepted all the conditions, stipulated in the tender specification, notwithstanding any exemptions mentioned therein.

**10. Right to reject/accept any tender:**

The purchaser reserves the right either to reject or to accept any or all tenders if the situation so warrants in the interest of the purchaser. Orders may also be split up between different Tenderers on individual merits of the Tenderer. The purchaser has exclusive right to alter the quantities of materials/ equipment at the time of placing final purchase order. After placing of the order, the purchaser may defer the delivery of the materials. It may be clearly understood by the Tenderer that the purchaser need not assign any reason for any of the above action [s].

**11. Supplier to inform himself fully:**

The supplier shall examine the instructions to tenderers, general conditions of contract, specification and the schedules of quantity and delivery to satisfy himself as to all terms and conditions and circumstances affecting the contract price. He shall quote price [s] according to his own views on these matters and understand that no additional allowances except as otherwise provided there in will be admissible. The purchaser shall not be responsible for any misunderstanding or incorrect information, obtained by the supplier other than the information given to the supplier in writing by the purchaser.

**12. Patent rights Etc.**

The supplier shall indemnify the Purchaser against all claims, actions, suits and proceedings for the infringement of any patent design or copy right protected either in the country of origin or in India by the use of any equipment supplied by the manufacturer. Such indemnity shall also cover any use of the equipment, other than for the purpose indicated by or reasonably to be inferred from the specification.

**13. Delivery:-**

- [a] Time being the essence of the contract; the equipment shall be supplied within the delivery period, specified in the contract. The Purchaser, however, reserves the right to reschedule the delivery and change the destination if required. The delivery period shall be reckoned from the date of placing the Letter of Intent/Purchase order, as may be specified in LOI/Purchase order.
- [b] The desired delivery period shall be as indicated at Annexure-III (Quantity & Delivery Schedule) of Section-IV (Technical Specification).

**14. Despatch instructions.**

- I] The equipment/ materials should be securely packed and dispatched directly to the specified site at the supplier's risk by Road Transport only.
- II] **Loading & unloading of Ordered Materials.**

It will be the sole responsibility of the supplier for loading and unloading of materials both at the factory site and at the destination site/store.

The Purchaser shall have no responsibility on this account.

**15. Supplier's Default Liability.**

- [i] The Purchaser may, upon written notice of default to the supplier, terminate the contract in circumstances detailed hereunder.
- [a] If in the judgement of the Purchaser, the supplier fails to make delivery of equipment/material within the time specified in the contract or within the period for which if extension has been granted by the Purchaser in writing in response to written request of the supplier.
- [b] If in the judgement of the Purchaser, the supplier fails to comply with any of the provisions of this contract.
- [ii] In the event, Purchaser terminates the contract in whole or in part as provided in Clause-15 (I) of this section, the Purchaser reserves the right to purchase upon such terms and in such a manner as he may deem appropriate in relation to the equipment/material similar to that terminated and the supplier will be liable to the Purchaser for any additional costs for such similar equipment/material and/or for penalty for delay as defined in clause-22 of this section until such reasonable time as may be required for the final supply of equipment.
- [iii] In the event the Purchaser does not terminate the contract as provided in clause 15(I) of this Section, supplier shall be liable to the Purchaser for penalty for delay as set out in Clause-22 of this section until the equipment is accepted. This shall be based only on written request of the supplier and written willingness of the Purchaser.

**16 Force Majeure:**

The supplier shall not be liable for any penalty for delay or for failure to perform the contract for reasons of force majeure such as acts of god, acts of the public enemy, acts of Govt., Fires, floods, epidemics, Quarantine restrictions, strikes, Freight Embargo and provided that the supplier shall within Ten (10)days from the beginning of delay on such account notify the purchaser in writing of the cause of delay. The purchaser shall verify the facts and grant such extension, if facts justify .

**17. Extension of time:-**

If the delivery of equipment/material is delayed due to reasons beyond the control of the supplier, the supplier shall without delay give notice to the purchaser in writing of his claim

for an extension of time. The purchaser on receipt of such notice may or may not agree to extend the contract delivery date as may be reasonable but without prejudice to other terms and conditions of the contract.

**18. Guarantee period: -**

[i] The materials covered by this specification should be guaranteed for satisfactory operation and against defects in design, materials and workmanship for a period of at least **36 [Thirty six] months** from the last date of delivery (In case of delivery in multiple stages, the last date of delivery of each stage delivery shall be considered for this purpose). The above guarantee certificate shall be furnished in triplicate to the purchaser for his approval. Any defect noticed during this period should be rectified/replaced by the supplier free of cost to the purchaser provided such defects are due to faulty design, bad workmanship or bad materials used, within one month upon written notice from the purchaser failing which provision of clause 22 (ii) shall apply.

[ii] The supplier's liability shall be to the extent of repair/ replacement of such defective equipment/material either arising from faulty design or defective equipment/materials and or bad workmanship. Such defective equipment/materials shall be handed over to the supplier for repair or replacement by a new one, unless otherwise repairable at site. The supplier shall complete the repair/replacement work within the reasonable time frame (as mentioned in clause 22(ii) intimated by OPTCL.

If it becomes necessary for the supplier to replace or repair any defective portions of the equipment/materials the provision of this clause shall apply to portion of the equipment/materials so replaced or repaired until the expiry of the guarantee period.

**19 B.G. towards security deposit, 100% payment and performance guarantee:**

[i] For manufacturers situated inside & out side the state of Orissa.

A Composite Bank Guarantee as per the Proforma enclosed at Annexure-VII of the specification for 10%(ten percent) of the Total Landing cost (Taxable Value plus GST thereon) of the purchase order (In case of successful bidder who is a local Micro and small Enterprise(MSEs)based in Odisha registered with respective DICs, Khadi, Village, Cottage & Handicrafts Industries, OSIC and NSIC 5%(Five percent), shall be furnished from any nationalized/scheduled bank having a place of business at Bhubaneswar, to the office of Sr.General Manager [Central Procurement Cell] OPTCL within 15 days from the date of issue of the purchase order. The BG shall be executed on non judicial stamp paper worth of Rs.29.00 [Rupees twenty nine] only or as per the prevalent rules, valid for a period of **20** 38-months from the last



date of stipulated delivery period, for scrutiny and acceptance, failing which the supply order will be liable for cancellation without any further written notices. The BG should be accompanied by a confirmation letter from the concerned bank and should have provision for encashment at Bhubaneswar, before the Bank Guarantee is accepted and all concerned intimated. The B.G should be revalidated as and when intimated to you to cover the entire guarantee period.

- [ii]** No interest is payable on any kind of Bank Guarantee.
- [iii]** In case of non-fulfillment of contractual obligation, as required in the detailed purchase order/Specification, the composite Bank guarantee shall be forfeited.
- [iv]** The performance bank guarantee should be submitted by the supplier within 01 month of issue of purchase order. However in case of segregation of delivery of materials in stages, the supplier shall submit single BG of specified amount as stated above on total award cost with validity of BG covering the entire guarantee period from the scheduled date of delivery of last stage plus 2 months.

**20. Import License**

In case imported materials are offered, no assistance will be given for release of Foreign Exchange. The firm should arrange to import materials from their own quota. Equipment of indigenous origin will be preferred.

**21. (A) Terms of Payment.**

- (i) 90% of the Taxable value of Battery & charger with Goods and Services Tax in full as applicable will be paid on receipt of materials in good condition at stores/desired site and verification thereof, subject to approval of 10% Composite Bank Guarantee (In case of successful bidder who is a local Micro and small Enterprise(MSEs),based in Odisha & registered with respective DICs, Khadi, Village, Cottage & Handicrafts Industries, OSIC and NSIC 5%(Five percent), of the cost of supplied materials, as stipulated under clause-19 of this specification & on prior approval of guarantee certificate & Test certificate by the Purchaser. ~~The buy-back price shall be deducted from the first 90% payment and OPTCL will issue receipt voucher/Tax Invoice towards amount deducted towards buy-back.~~

Balance 10% of the Taxable Value of Battery Charger along with commissioning charges, if any, shall be paid after successful erection & commissioning of chargers along with battery sets at the required site, on issuance of taking over certificate by the concerned site-in-charge.

ii) TDS under **Income Tax Act** and GST Laws shall be deducted, if applicable.

Any imposition of new tax or revision of tax shall be paid/reimbursed at the time of dispatch, scheduled or actual whichever is lower (i.e. If delivery is within schedule period, tax variation as applicable shall be paid, and if delivery is made beyond schedule date, any additional financial implication due to statutory variation in tax shall be to bidder's account)

**[B]** The supplier shall furnish Composite Bank Guarantee of appropriate amount to OPTCL covering **10%** of F.O.R. Destination cost of the purchase order well in advance (within 15 days from the date of issue of the purchase order) before despatch of materials.

**22. Price Reduction Schedule for Delay in Completion of Supply under Purchase Order/Contract**

(i) If the Supplier fails to deliver the materials/equipment within the delivery schedule, specified in the Purchase Order/Contract including delivery time extension, if any, granted with waiver of Price Reduction Schedule, the Purchaser shall recover from the Supplier, Price Reduction Schedule for a sum of half per cent (0.5 per cent) of the Taxable Value of the un-delivered equipment /materials for each calendar week of delay or part thereof. For this purpose, the date of receipted challan shall be reckoned as the date of delivery. The total amount of Price Reduction Schedule shall not exceed five per cent (5%) of the Taxable Value of the un-delivered equipment/materials. Equipment will be deemed to have been delivered only when all its components, accessories and spares as per technical Specification are also delivered. If certain components, accessories and spares are not delivered in time, the equipment/materials will be considered delayed until such time as the missing components, accessories and spares are delivered.

(ii) During the guarantee period, if the Supplier fails to rectify/replace the equipment/material within 30 days from the date of intimation of defect by the purchaser, then the Price Reduction Schedule at the rate of half percent (0.5%) of the Total Taxable Value for each calendar week of delay or part thereof shall be recovered by the purchaser. For this purpose, Price Reduction Schedule shall be reckoned from the 30th day from the date of issue of letter on defectiveness of equipment/material. The total amount of Price Reduction Schedule in this case shall not exceed 10% (TEN PERCENT) of the Purchase Order/Contract amount except GST (i.e. Total Taxable Value). If the defects, so intimated are not rectified or equipment/materials not replaced by the supplier within the guarantee period, then whole of the C.P.B.G. will be forfeited by the purchaser, without any intimation to the supplier.

**23. Insurance**

The Supplier shall undertake insurance of stores covered by this Specification unless otherwise stated. The responsibility of delivery of the stores at destination in good condition rests with the Supplier. Any claim with the Insurance Company or transport agency arising due to loss or damage in transit has to be settled by the supplier. The Supplier shall undertake free replacement of materials damaged or

lost, which will be reported by the consignee within 30 days of receipt of the materials at destination without awaiting for the settlement of their claims with the carriers and underwriters.

**24. Payment Due from the Supplier.** All costs and damages, for which the supplier is liable to the purchaser, will be deducted by the purchaser from any money, due to the supplier, under any of the contract (s), executed with OPTCL.

**25. Rating under Goods and Services Tax and Balance sheet and profit & Loss Account:**

- i. Rating under Goods and Services Tax shall be enclosed with the tender.
- ii. Audited Balance Sheet and Profit & Loss Account of the bidder for the previous three years shall be enclosed to assess the financial soundness of the bidder(s).
- iii. iii. GST registration certificate and PAN Card Copy.
- iv. iv. Tax holiday/exemption certificate under GST or any other Act.
- v. v. TDS exemption certificate under the Income Tax Act or any other act.

**26. Certificate of Exemption from Goods and Services Tax.**

Offers with exemption from Goods and Services Tax shall be accompanied with authenticated proof of such exemption. Authenticated proof for this clause shall mean attested Photostat copy of exemption certificate. Any claim towards Goods and Services Tax shall be paid on actual basis subject to production of authenticated documentary evidence.

**27. Supplier's Responsibility.**

Notwithstanding anything mentioned in the Specification or subsequent approval or acceptance by the Purchaser, the ultimate responsibility for design, manufacture, materials used and satisfactory performance shall rest with the Tenderers. The Supplier(s) shall be responsible for any discrepancy noticed in the documents, submitted by them along with the bid(s)

**28. Validity.**

Prices and conditions contained in the offer should be kept valid for a minimum period of 180 days from the date of opening of the tender, failing which the tender shall be rejected.

**29. EVALUATION.**

**(i)** Evaluation of bids will be on the basis of the FOR DESTINATION PRICE (By Road Transport) including Goods and Services Tax & other levies as may be applicable plus installation & commissioning charges ~~after deducting the buy-back price of old batteries(the quoted buy back price shall remain constant).~~

The FORD PRICE shall consist of the following components

- a) Taxable value of equipment/materials
- b) Goods and Services Tax

- c) Other levies.
- d) Mandatory spares, if any for maintenance of equipment. (At the discretion of the purchaser)
- e) Test charges, if any.
- f) Supervision of erection, testing and commissioning charges, if any.
- g) Any other items, as deemed proper for evaluation by the purchaser.
- h) Loading factors will be taken in to account during evaluation if the prices of some of the items, not quoted.
- i) Any imposition of new tax or revision of tax shall be considered at the time of price bid evaluation.

**(II) Weightage shall be given to the Following factors in the Evaluation & Comparison of Bids.**

In comparing bids and in making awards, the Purchaser will consider other factors such as compliance with Specification, minimum qualification criteria as per clause-30, outright rejection of tenders clause-34 of this tender, relative quality, adaptability of Supplies or services, experience, financial soundness, record of integrity in dealings, performance of materials/equipments earlier supplied, ability to furnish repairs and maintenance services, the time of delivery, capability to perform including available facilities such as adequate shops, plants, equipment and technical organization.

- (III)** The local MSE (In the state of Odisha) bidders shall be required to furnish their willingness to match their bid price with that of the lowest evaluated bidder without any price preference and in case they agree, they shall be eligible to get up to 30% of the tendered quantity to be distributed suitably among the willing MSE (In the state of Odisha) bidders failing which the said 30% of the tendered quantity be awarded to the lowest evaluated bidder.

**Reverse Auction is hereby incorporated in the referred tender as follows.**

<b>STRATEGY FOR E-REVERSE AUCTION</b>	
1	Bidders are required to go through the guide lines given below and submit their acceptance to the same.
2	e-Reverse Auction (RA) will be conducted in e-tender portal of OPTCL on specified date and time, while bidders shall quote from their own offices/places of their choice. Internet connectivity shall be ensured by the respective agencies/bidders themselves.
3	Demonstration/ training (if not trained earlier) of bidder's nominated person(s), shall be done to explain all the rules related to e-Reverse Auction/ Business Rule document to be adopted.
4	The strategy to be used for reverse auction shall be "DYNAMIC TEMPLATE BIDDING"
<b>Procedure for electronic Reverse Auctioning (e-RA):</b>	

5	<p>a. The e-RA shall be conducted on <a href="http://www.tenderwizard.com">www.tenderwizard.com</a> only.</p> <p>b. Bidder has to submit letter towards agreement to the Process related Terms &amp; Conditions for e-Reverse Auction, as per (Reverse Auction Process Compliance Form at Annexure-IB). In non-receipt of the same, vendors will not be allowed to participate in e-RA.</p> <p>c. e-RA shall be carried out after opening of Price bids and completion of Price bid evaluation, which will be intimated only to the techno-commercially qualified bidders by OPTCL as per procedure given below.</p> <p>d. OPTCL reserves the right to conduct e-RA and it is obligatory on part of bidder(s) invited to participate in e-RA process once they have responded to the techno-commercial bid.</p>
6	<p>Prior intimation/ Notice for RA invitation will be given to techno-commercially qualified bidders regarding the date &amp; time of opening of the e-RA.</p> <p>The start bid price (SBP) for e-Reverse Auction of each bidder under a particular package shall be the L1 evaluated price for the subject package including Taxes &amp; Duties for the total scope for subject Package. Taking the above discovered L1 price as the upper limit e-RA will be conducted to determine the lowest possible price.</p> <p>Reverse Auction will be conducted amongst first 50% of the technically qualified bidders arranged in order of prices from lowest to highest, as L1, L2,L3-----Ln, and L1 price will be discovered. Minimum of 3 bidders shall be eligible for e RA. (eg. If 4 bidders are financially evaluated then the L1, L2 and L3 bidders shall be eligible for e-RA). Number of bidders eligible for participating in RA would be rounded off to next higher integer value if number of technically qualified bidders is odd (e.g. if 7 bids are technically qualified, then RA will be conducted amongst L1 to L4).</p> <p>However, in case only two bidders are found to be responsive, e-RA would be carried out with both the parties without any elimination. However, OPTCL reserves the right to invite the evaluated L1 bidder for negotiation without conducting the e-RA.</p> <p>In case of price submitted by any bidder is found to be abnormal, OPTCL reserves the right to reject the bid of the bidder(s) .</p> <p>Rank of bidders would be displayed as per the total cost to OPTCL, i.e including Taxes and Duties payable by OPTCL as per the provisions of the bidding document &amp; after e-RA process is over.</p>
7	<p>Names of bidders/ vendors shall not be disclosed during the e-RA process. Names of bidders/ vendors shall be anonymously masked in the e-RA process.</p> <p>(i) In case of RA, start/ reference price and step value of decrement shall be indicated to the bidders at the start of the auction. Any participating bidder can bid one or multiple step decrement lower than the prevailing lowest bid at that time. The Bidder shall be able to view Bid</p>

	<p>Start Price, Bid Decrement Value, Prevailing Lowest Bid value, last Bid Placed by him and time left for bidding.</p> <p>(ii) The step value of decrement in a package to be offered by bidder (the minimum amount of reduction in the total bid price including all taxes &amp; duties during auction) , shall be kept at 0.15% of L1 bidder's final evaluated price (or) at approved amount as decided by OPTCL.</p> <p>(iii) Bidders can only quote any value lower than their previous quoted price. However, at no stage, increase in Price will be permissible.</p> <p>(iv) At any point during Reverse Auction, bidding Price field shall remain enabled for the bidders. The total reverse auction period shall be unlimited &amp; the initial auction period (1<sup>st</sup> slot) will be of thirty (30) minutes with provision of auto extension by (10) ten minutes from the schedule/ extended closing time. If any fresh lower bid is received in last ten minutes of auction period or extended auction period, the auction shall get extended automatically for another 10 minutes. In case, there is no bid received during schedule/extended slot, the Auction shall get closed automatically without further extension.</p> <p>(v) However, bidders are advised not to wait till the last minute or last few seconds to enter their bid during the period of e-reverse auction to avoid complication related with internet connectivity, network problem, system crash down, power failure etc.</p>
8	<p>After conclusion of e-Reverse Auction i.e (Closing Price in Reverse Auction will be taken as offered price by the L1 bidder), decrease in price of individual head of the template shall be considered proportionately on all individual line items of the respective head of the price schedule of the successful L1 bidder .</p> <p>Any bid received at the tender wizard server end subsequent to closure of the e-RA shall be summarily rejected and shall not be considered as a valid bid under whatsoever circumstances. For this purpose, tender wizard server log shall prevail.</p> <p>The bidder shall not involve himself or any of his representatives in price manipulation of any kind directly or indirectly by communicating with other bidders.</p> <p>During Reverse Auction, If no bid is received within the specified time, OPTCL, at its discretion, may decide to close the reverse auction process/ proceed with conventional mode of tendering [ Evaluation of Part-II (price bid) submitted by bidders earlier].</p>
9	<p>Consequent upon completion of e-Reverse Auction, OPTCL's decision on award of contract shall be final and binding on the bidders.</p> <p>OPTCL shall be at liberty to call the L1 bidder for further process/ negotiation and also at liberty to cancel the e-reverse auction process/ re-tender at any time, without assigning any reason thereof. OPTCL can</p>

	<p>decide to reschedule or cancel any reverse auction: the bidders shall be informed accordingly.</p> <p>OPTCL/ Service Provider shall not have any liability to bidders for any interruption or delay in access to the e-Tender site/ Reverse Auction link irrespective of the cause.</p>
	<p><b>(Reverse Auction Process Compliance Form) (Annexure-IB)</b>          (To be incorporated in the bid document).          (To be submitted on letter head of the bidding company with sign and stamp and along with Technical bid)          To,          CGM (CPC), OPTCL          Bhubaneswar-751010, Odisha</p> <p>Sub: Agreement to the Process related Terms &amp; Conditions for e-Reverse Auction.          Dear Sir,</p> <p>This letter is to confirm that:</p> <ul style="list-style-type: none"> <li>• The undersigned is authorized representative of the company.</li> <li>• We have studied the Commercial Terms and the Business rules governing the Reverse Auction as mentioned in your tender and confirm our agreement to that.</li> <li>• We also confirm that we have gone through the auction manual and have understood the functionality of the same thoroughly.</li> <li>• We, hereby, confirm that we will honour the Bids placed by us during the tendering/ e- Reverse auction process as called as e-RA.</li> <li>• We also confirm that we will accept our Rank / Position that will be displayed when the Bidding Time for the Online Reverse Auction is over.</li> </ul> <p style="text-align: center;">With regards,          Signature with Designation with company seal Name &amp; Address</p> <p>Person having power of attorney for the subject package.</p>

**30. Minimum Qualification Criteria of Bidders.**

All the prospective bidders are requested to note that their bids for tendered equipment can only be considered for evaluation if:

- i) The bidder should have manufacture and supply experience of above rated or higher capacity equipment for a minimum period of 3 (three) years as on the date of opening of the tender.
- ii) At least 50% of the tendered quantity of above rated or higher capacity equipment should have been supplied, erected, tested and commissioned within the above-stipulated period. [**Note:** “within above stipulated period:- within 3(three) years from the date of opening of this tender].

- iii) The above rated or higher capacity equipment should have at least 2 (two) years successful performance from the date of commissioning. At least one of the performance certificates shall be submitted from Govt. of India/State Govt.(s) or their undertakings.
- iv) The bidder should have conducted type tests on the tendered equipments in Government approved laboratory within five years from the date of opening of the tender.
- v) The Bidder must possess bureau of Indian Standard Certification (ISI mark).
- vi) The bidder must possess valid ISO 9001:2008 certification for Manufacturer/Supplier.
- vii) The Bidder should have adequate infrastructural facility for “After sales service”
- viii) Copies of documents, defining the constitution or legal status, place of registration and principal place of business of the company or firm or partnership or collaborator or parent Company etc. shall be furnished along with the bid.
- ix) Even though the Bidders meet the above qualifying criteria, they are subject to be disqualified if they have
- x) Made misleading or false representations in the forms, statements and attachments, submitted in proof of qualification requirements and/ or
- xi) Record of poor performance such as not properly completing the contract, inordinate delays in completion of supply, litigation history or financial failure etc.
- xii) Notwithstanding anything stated above, the purchaser reserves the right to assess the Bidder’s capability & capacity to perform the contract should circumstances warrant such an assessment in the overall interest of the purchaser.

**Registration certificate of DPIIT:**

As per Office Memorandum No.F.No.6/18/2019-PPD, Ministry of Finance, Dept. of Expenditure Public Procurement Division, New Delhi and Office Memorandum No. FIN-CON-MISC-0007/2019/27945/F Dated.16.10.2020 of Finance Department, Govt. of Odisha “Any bidder from a country which **shares a land border with India** will be eligible to bid in any procurement whether goods, services (Including consultancy services and non-consultancy services) or works (including turnkey projects) **only if the bidder is registered with the Competent Authority, DPIIT (i.e. Department for Promotion of Industry and Internal Trade)**”. Pursuant to decision of Govt. of India prescribing imposition of restriction on public procurement from bidders of certain countries on ground of defence of India or matters directly or indirectly related thereto, the Office Memorandum No. 4939/F, dated: 13.02.2012 of Finance Department, Govt of Odisha has been amended vide Office



Memorandum No 27945 Dtd 16.10.2020 by inserting sub-para-3 (vii) to para-3 thereof. Prescribing the restriction on procurement made by the State Govt., State Public Sector Undertaking including local bodies etc. and directing no procurement shall be made in violation of such restrictions, it is hereby clarified that the provisions of the same shall be applicable for the tenders for works/procurement/Service in OPTCL in both ongoing (Techno-Commercial bid not opened) and future tenders.

The tender documents of OPTCL shall contain following additional clauses and certificate formats.

<b>A. To be incorporated as qualifying requirement of bidder /certificates in case of tenders for Works (including Turn-key works)</b>	
I.	Any bidder from a country which shares a land border with India will be eligible to bid in this tender only if the bidder is registered with the Competent Authority as per requirement of Govt. of India.
II.	“Bidder” (including the term ‘tenderer’, ‘consultant’ or ‘service provider’ in certain contexts) means any company, including any member of a consortium or joint venture (that is a company ),
III.	“Bidder from a country which shares a land border with India” for the purpose of this Order means :- a. An entity incorporated, established or registered as company in such a country ; or b. A subsidiary company of an entity incorporated, established or registered in such a country ‘ or c. An entity substantially controlled through entities incorporated , established or registered in such a country ; or d. An entity whose beneficial owner is situated in such a country ; or e. An Indian (or other) agent of such an entity ; or f. A consortium or joint venture where any member of the consortium or joint venture falls under any of the above.
IV.	The beneficial owner for the purpose of (iii)(d) above will be as under : <b>1.</b> In case of a company the beneficial owner is the natural person(s), who, whether acting along or together, or through one or more juridical person, has a controlling ownership interest or who exercises control through other means. <b>Explanation-</b> a. “Controlling ownership interest” means ownership of or entitlement to more than twenty-five per cent of shares or capital or profits or the company. b. “Control” shall include the right to appoint majority of the directors or to control the management or policy decisions including by virtue of their shareholding or management rights or shareholders agreements or voting agreement; <b>2.</b> Where no natural person is identified under (1) above, the beneficial owner is the relevant natural person who hold the position of senior managing official ;
V.	An Agent is a person employed to do any act for another, or to represent another in dealings with third person.
VI.	The successful bidder shall not be allowed to sub-contract works to any contractor from a country which shares a land border with India unless such contractor is registered with the Competent Authority.

**Certificate ( to be furnished in bidder company’s letter head)**

I have read the clause regarding restrictions on procurement from a bidder of a country which shares a land border with India and on sub-contracting to contractors from such countries; I certify that this bidder is not from such a country or, if from such a country, has been registered with the Competent Authority and will not sub-contract any work to a contractor from such countries unless such contractor is registered with the Competent Authority. I hereby certify that this bidder fulfils all requirements in this regard and is eligible to be considered. [Where applicable evidence of valid registration by the Competent Authority shall be attached.

**B. To be incorporated as qualifying requirement of bidder /certificates in case of tenders for procurement of goods/services(including consultancy and non-consultancy)**

- I. Any bidder from a country which shares a land border with India will be eligible to bid in this tender only if the bidder is registered with the Competent Authority as per requirement of Govt. of India
- II. “Bidder” (including the term ‘tenderer’, ‘consultant’ or ‘service provider’ in certain contexts) means any person or firm or company, including any member of a consortium or joint venture (that is an association of several persons, or firms or companies), every artificial juridical person not falling in any of the descriptions of bidders stated herein before, including any agency branch or office controlled by such person, participating in a procurement process.
- III. “Bidder from a country which shares a land border with India” for the purpose of this Order means :-
  - a. An entity incorporated, established or registered in such a country ; or
  - b. A subsidiary of an entity incorporated, established or registered in such a country ‘ or
  - c. An entity substantially controlled through entities incorporated , established or registered in such a country ; or
  - d. An entity whose beneficial owner is situated in such a country ; or
  - e. An Indian (or other) agent of such an entity ; or
  - f. A natural person who is a citizen of such a country ; or
  - g. A consortium or joint venture where any member of the consortium or joint venture falls under any of the above.
- IV. The beneficial owner for the purpose of (iii)(d) above will be as under :
  - 1. In case of a company or Limited Liability Partnership, the beneficial owner is the natural person(s), who, whether acting along or together, or through one or more juridical person, has a controlling ownership interest or who exercises control through other means.

**Explanation-**

- a. “Controlling ownership interest” means ownership of or entitlement to more than twenty-five per cent of shares or capital or profits or the company.
- b. “Control” shall include the right to appoint majority of the directors or to control the management or policy decisions including by virtue of

their shareholding or management rights or shareholders agreements or voting agreement;

2. In case of a partnership firm, the beneficial owner is the natural person(s) who, whether acting along or together, or through one or more juridical person, has ownership or entitlement to more than fifteen per cent of capital or profits of the partnership ;
  3. In case of an unincorporated association or body of individuals, the beneficial owner is the natural person(s), who, whether acting along or together, or through one or more juridical person, his ownership or entitlement to more than fifteen per cent of the property or capital or profits of such association or body of individuals ;
  4. Where no natural person is identified under (1) or (2) or (3) above, the beneficial owner is the relevant natural person who hold the position of senior managing official ;
  5. In case of a trust, the identification of beneficial owner(s) shall include identification of the author of the trust, the trustee, the beneficiaries with fifteen per cent or more interest in the trust and any other natural person exercising ultimate effective control over the trust through a chain of control or ownership.
- V. An Agent is a person employed to do any act for another, or to represent another in dealings with third person.

**Certificate ( to be furnished in bidder's letter head)**

I have read the clause regarding restrictions on procurement from a bidder of a country which shares a land border with India; I certify that this bidder is not from such a country or, if from such a country, has been registered with the Competent Authority. I hereby certify that this bidder fulfils all requirements in this regard and is eligible to be considered. [Where applicable, evident of valid registration by the Competent Authority shall be attached.]

**31. Jurisdiction of the High Court of Orissa.**

Suits, if any, arising out of this contract shall be filed by either Party in a court of Law to which the jurisdiction of High court of Orissa extends.

**32. Correspondences.**

- i) Any notice to the supplier under the terms of the contract shall be served by Registered Post or by hand at the Supplier's Principal Place of Business.
- ii) Any notice to the Purchaser shall be served at the Purchaser's Principal Office in the same manner.

**33. Official Address of the Parties to the Contract**

The address of the parties to the contract shall be specified:-

- [i] **Purchaser:** Senior General Manager (Procurement)(CPC) OPTCL  
Bhubaneswar-751022 (Orissa)

Telephone No. 0674 - 2541801

FAX No. 0674 - 2542964

- [ii] **Supplier:** Address  
Telephone No.  
Fax No.

#### **34. Outright Rejection of Tenders**

Tenders shall be outrightly rejected if the followings are not complied with.

- [i] The tenderer shall submit the bid in electronic mode only in e-tender portal and shall submit the tender paper cost (Cost of Tender Spec.) online through e-payment gateway link provided in e-tender portal (by using Net Banking, Debit Card or Credit Card) prior to last date & time of submission of online tender..  
In case of local Micro and small Enterprises(MSEs)based in Odisha registered with respective DICs, Khadi, Village, Cottage & Handicrafts Industries, OSIC and NSIC participating in the tender they have to submit notarised hard copy of registration as local MSE (In the state of Odisha) as above on or before the date and time of submission of technical bid.
- [ii] The tenderer shall submit the bid in electronic mode only
- [iii] The Tender shall not be submitted telegraphically or by FAX.
- [iv] The prescribed EMD shall be submitted on or before the date and time of submission of technical bid.
- [v] The Tender shall be kept valid for a minimum period of 180 days from the date of opening of tender.
- [vi] The Tender shall be submitted in two parts as specified.
- [vii] The Tenders shall be accompanied by a list of major supplies effected prior to the date of opening of tender. Data of at least 3 (three) years shall be furnished.
- [viii] The tenderer shall upload the scanned copy of latest type test certificates (for the tests, carried out on the tendered equipments, being offered). Such type tests should have been conducted within last five years from the date of opening of this tender in a Government approved laboratory/CPRI in presence of any Government Organisation's representative(s).
- [ix] The schedule of prices should be filled up fully to indicate the break-up of the prices including taxes and duties. Incomplete submission of this schedule will make the tender liable for rejection. Vide Clause-4(ii) of Part-II.
- [x] The Tenderer should quote 'FIRM' price only and the price should be kept valid for a minimum period of 180 days from the date of opening of the tender.
- [xi] The tenderer shall upload the scanned copy legibly written user's certificate to prove the satisfactory operation of the offered equipments/materials for a minimum period of 2 (two) years from the date of commissioning/use as per the tender specification. User's certificate shall include the detailed address of the user with

Equipment/Material, Name and type as per this specification, number of years of satisfactory use/operation & date of issue of this user's certificate with official seal written in English only & clearly visible must be furnished. At least one of the user's certificates shall be from state or Central Govt. or their Undertakings.

- (xii) Guaranteed Technical particulars & Abstract of terms and Conditions should be filled in completely.
- (xiii) (a) Detailed information on any litigation or arbitration arising out of contract completed or under execution by it over the last five years. A consistent history of litigation by or against the bidder may result in rejection of bid.  
 (b) The bidder should not have any pending litigation or arbitration with OPTCL with regard to any project or related activity. The bidder should certify / declare the same in the unequivocal terms by way of an affidavit duly sworn before a magistrate or a notary. Bid furnished by the bidder shall not be eligible for consideration if it is not accompanied by the affidavit. Further the bid / LOA/ LOI shall be liable for outright rejection/ cancellation at any stage if any information contrary to the affidavit / declaration is detected.

**35. Documents to be treated as confidential.**

The supplier shall treat the details of the specification and other tender documents as private and confidential and these shall not be reproduced without written authorization from the Purchaser.

**36. Scheme/Projects**

The materials/equipment covered in this specification shall come under "O&M WORKS "

**SECTION - III.**

***LIST OF ANNEXURES***

**[ I TO XII ]**

**[ PAGE 30 TO 48 ]**

**SECTION - III**

**[LIST OF ANNEXURES]**

The following schedules and proforma are annexed to this specification and contained in Section-III as referred to in the relevant clauses.

1.	Declaration form	ANNEXURE-I
2.	E-Reverse Auction Compliance Form	ANNEXURE-I(B)
3.	Abstract of terms and conditions to accompany Section-II of Part-I	ANNEXURE-II
4.	Schedule of Quantity and Delivery	ANNEXURE-III
5..	Abstract of price component [to accompany Part-II of this specification]	ANNEXURE-IV

6.	Schedule of prices to accompany Part-II	ANNEXURE-V
7.	Bank Guarantee form for earnest money deposit	ANNEXURE-VI
8.	Composite Bank Guarantee form for security deposit, payment and performance	ANNEXURE-VII
9.	Chart showing particulars of E.M.D.	ANNEXURE – VIII
10.	Data on Experience.	ANNEXURE – IX
11.	Schedule of spare parts.	ANNEXURE-X
12.	Schedule of Installations.	ANNEXURE-XI
13.	Schedule of deviations(Technical)	ANNEXURE-XII(A)
14.	Schedule of deviations(Commercial)	ANNEXURE-XII(B)
15.	Litigation/Arbitration	ANNEXURE-XIII
16.	<b>DPIIT Certificate</b>	<b>ANNEXURE-XIV</b>
17.	Affidavit of bidder	ANNEXURE-XV

LIST of Documents

The following documents are to be attached in the below name

- 1.PAN
- 2.GSTIN
- 3.Income tax return
- 4.Audited B/s & Profit loss account
5. Certificate of incorporation
6. E payment proof of tender cost

**ANNEXURE - I**  
**DECLARATION FORM**

**To**

The Sr. General Manager (CPC)  
OPTCL Head Qrs.BBSR,751022

Sub:- Tender Specification No-\_\_\_\_\_

Sir,

1. Having examined the above specification together with terms & conditions referred to therein \* I/We the undersigned hereby offer to supply the materials/equipment covered therein complete in all respects as per the specification and General conditions, at the rates, entered in the attached contract schedule of prices in the Tender.
2. \* I/We hereby undertake to have the materials/equipment delivered within the time specified in the Tender.

3. \* I/We hereby guarantee the technical particulars given in the Tender supported with necessary reports from concerned authorities.
4. \* I/We certify to have submitted the bid electronically by remitting \*cash/money order/D.D./ remitting the cost of tender, herewith and this has been acknowledged by your letter/ money receipt No.                      Dated,
5. In the event of Tender, being decided in \*my/our favour, \* I/We agree to furnish the Composite B.G. in the manner, acceptable to ORISSA POWER TRANSMISSION CORPORATION LTD., and for the sum as applicable to \*me/us as per clause-19 of section-II of this specification within 15 days of issue of letter of intent/purchase order failing which \*I/We clearly understand that the said letter of Intent/Purchase order will be liable to be withdrawn by the purchaser.

**Bid Security Declaration**

~~\*I/We further declare that, we will not modify/withdraw the bid after opening of techno-commercial bid(i.e. part I bid) during its validity period and in such an event we agree that OPTCL would be free to debar us from participating in the tenders floated by OPTCL for a period of three years.~~

Signed this    day of    2025

Yours faithfully

Signature of the Bidder with seal of the company

[This form should be dully filled up by the Bidder and uploaded at the time of submission of tender.]

\* (Strikeout whichever is not applicable)

**(Annexure-IB)**  
**(Reverse Auction Process Compliance Form)**

(To be submitted on letter head of the bidding company with sign and stamp and along with Technical bid)

To  
The Sr. General Manager (CPC),  
OPTCL, Bhubaneswar-751010, Odisha

Sub: Agreement to the Process related Terms & Conditions for e-Reverse Auction.

Dear Sir,

This letter is to confirm that:

- The undersigned is authorized representative of the company.
- We have studied the Commercial Terms and the Business rules governing the Reverse Auction as mentioned in your tender and confirm our agreement to that.
- We also confirm that we have gone through the auction manual and have understood the functionality of the same thoroughly.
- We, hereby, confirm that we will honour the Bids placed by us during the tendering/ e- Reverse auction process as called as e-RA.
- We also confirm that we will accept our Rank / Position that will be displayed when the Bidding Time for the Online Reverse Auction is over.

With regards,

Signature with Designation with company seal

Name & Address of Person having power of attorney for the subject package.



**ANNEXURE-II****ABSTRACT OF GENERAL TERMS AND CONDITIONS OF CONTRACT [COMMERCIAL]**  
**TO ACCOMPANY PART-I**

(To be filled up by the tenderer as indicated in the excel sheet)

1	Whether the material/equipment offered conforms to the OPTCL'S specification (If not, specify the deviations in Annexure).	Yes/No
2.a.i	Cost of Tender Document:	Submitted/Not submitted
2.a.ii	OPTCL Money Receipt No. & Date / D.D No & Date.	
2.b.i	Earnest money furnished.	Submitted/Not submitted
2.b.ii	Bank Guarantee No. & Date / D.D No. & Date.	
2.c.i	Tender Processing Fee:	Submitted/Not submitted
2.c.ii	D.D No. & Date.	
3	Manufacturer's supply experience including user's certificate uploaded or not. [As per clause No.7 of Section-II.]	Yes/No
4.a.i	Commercial Deviations to the specification if any	Yes/No
4.a.ii	If Yes, [list uploaded or not, As per clause-9 of the Section-II]	Yes/No
4.b.i	Technical Deviations to the specification if any	Yes/No
4.b.ii	If Yes, list uploaded or not, As per clause-9 of the Section-II	Yes/No
5	Delivery (Period in months from the date of issue of PO)	
6	Guarantee: - Whether agreeable to OPTCL's terms[As per clause-18 of Section-II].	Yes/No
7	Whether agreeable to furnish Composite B.G. in case his tender be successful [As per clause-19 of Section-II]	Yes/No
8	Terms of payment:- Whether agreeable to OPTCL's terms or not [As per clause-21 of Section-II]	Yes/No
9	Nature of price:- FIRM	Yes/No
10	Price Reduction: - Whether agreeable to OPTCL's terms or not (As per clause- 22 of Section-II)	Yes/No
11	Whether STCC/ P&L A/C, Balance Sheet for the required period are uploaded as per clause-25 of Section-II	Yes/No
12	Validity: - Whether agreeable to OPTCL's terms or not[As per clause-28 of Section-II]	Yes/No
13	Whether recent type test certificates from any Government approved laboratory is uploaded or not. [As per clause-30[viii] of section-II]	Yes/No

14	Whether guaranteed technical particulars are uploaded or not	Yes/No
15	Whether dimensional design/drawings uploaded or not	Yes/No
16	Whether materials are ISI/ISO marked.	Yes/No
17	Manufacturer's name and its trademark	
18	Whether registered under GST Laws.	Yes/No
19	Whether declaration form, duly filled in, uploaded or not	Yes/No

**Place: -**

**Date: -**

**Signature of the Tenderer**

with seal of the company

**Place: -**

**Date: -**

**Signature of the Tenderer**

with seal of the company

### **ANNEXURE-III**

#### **SCHEDULE OF QUANTITY AND DELIVERY**

(To be filled up by the Bidder)

(To be filled up by the tenderer as indicated in the excel sheet)

SL No	Description of materials	Quantity required	Desired Delivery	Destination	Remarks.
1	2	3	4	5	6

Signature of Tenderer

with seal of Company

**ANNEXURE-IV**

*ABSTRACT OF PRICE COMPONENT [TO ACCOMPANY PRICEBID]*

(To be filled up by the tenderer as indicated in the excel sheet)

<b>Sl.No.</b>	<b>Description</b>	<b>To be filled by the bidder.</b>
1	Price basis	F.O.R. Purchaser's destination Stores/site.( Taxable value including packing forwarding, Freight, Insurance, unloading)
2	HSN Code of the Item	
3	GST Identification Number (GSTIN) of the firm	
4	Whether Intra-state supply(i.e. from inside Odisha) or Inter-state supply( i.e from outside Odisha). select from dropdown list	
5	Rate of CGST	
6	Rate of OGST.	
7	Rate of IGST.	
8	Rate of Goods and Services Tax on supervision of erection testing and commissioning	
9	Nature of price.	
10	We hereby undertake and declare that implication of lower Tax and Input Tax Credit benefit as per anti-profiteering (under Section 171 of CGST Act) and other provisions under GST Laws have been fully passed on to the purchaser while quoting the price.	Agreed
11	Any imposition of new tax or revision of tax shall be paid/reimbursed at the time of dispatch, scheduled or actual whichever is lower (i.e. If delivery is within schedule period, tax variation as applicable shall be paid, and if delivery is made beyond schedule date, any additional financial implication due to statutory variation in tax shall be to bidder's account). (Indicated- Yes/No)	

NB:- Abstract of price component shall be done for equipment/material offered, for testing & commissioning charges, if any. All the above prices will be taken during bid price evaluation

Place:  
Date:

Signature of the Bidder  
with seal of the company.

**ANNEXURE-V.**

**SCHEDULE OF PRICES**

**TENDER SPECIFICATION No.**

Item No.	Description.	Qty (unit)	Unit Taxable Value at destination store/ site including transformer oil & other accessories & testing as per spec.
1.	2.	3.	4.

<b>Unit GST</b>	Unit landing Cost including all taxes & Duties.	Total landing cost Including all taxes & duties.
<b>5.</b>	6= (4+5)	7= (6*3)

Erection Cost in INR Rs.			Grand Total amount in Rs.
Unit Erection Cost	Unit GST	Total Erection Cost	13+16
14	15	16	17

NB: -

- The tenderer should fill up the schedule properly and in full in Excel file of e-tender mode.** The tenderer should fill up the schedule properly and in full. The tender will be rejected, if the schedule of price is submitted in incomplete form. No post tender correspondence will be entertained on break-up of prices. Also, the supplier should agree for delivery at sub-station site.
- The Tenderer shall give an undertaking in part-I of the bid that, any implication of lower Tax and Input Tax Credit benefit have been fully passed on to the purchaser as per anti-profiteering and other provisions under GST Laws while quoting the tender price.
- Conditional offers will not be acceptable.

4. The bidder is to clearly indicate the period up to which the tax holidays are available to them.
5. Price bid in any other format will not be acceptable and the offer will be rejected.
6. All the above charges will be taken into account, during bid price evaluation.

ANNEXURE-VI

[PROFORMA FOR BANK GUARANTEE FORM FOR EARNEST  
MONEY DEPOSIT]

**(To be Stamped in accordance with Stamp Act and the Non-Judicial Stamp Paper of appropriate value should be in the name of Issuing Bank)**

**Ref No:** .....

**Bank Guarantee No.** .....

**Date:**.....

**BG Amount:**.....

**Validity Period:**.....

This Guarantee Bond is executed this..... day of ..... by us the..... Bank at ..... , P.O..... , Dist....., State..... and Code No.....

Whereas the ODISHA POWER TRANSMISSION CORPORATION Limited, Janpath, Bhubaneswar, a company constituted under the Companies Act-1956 (hereinafter called OPTCL) has invited Tender vide e-NIT No..... Dated..... for the purpose of ..... work under Package(s) No...../ purchase of ----- .

1. Now, therefore, in accordance with Notice Inviting Tender (e-NIT) No..... Dated ..... of OPTCL, Ms/Shri.....Address..... Wish / wishes to participate in the said tender and as a Bank Guarantee for the sum of Rs..... [ Rupees in *words*----- ] valid for a period of .....days is required to be submitted by the bidder, as per Tender Specification, we the \_\_\_\_\_ ) [indicate the name, Address & Code of the bank] [hereinafter referred to as “Bank”] at the request of Ms/Shri..... [hereinafter referred to as “Bidder”] do hereby unequivocally and unconditionally guarantee and undertake to pay during the above said period on written request by the <Tender Issuing Authority, Central Procurement Cell (CPC) ODISHA POWER TRANSMISSION CORPORATION Ltd. , Bhubaneswar an amount not exceeding Rs..... to OPTCL., without any reservation. The guarantee would remain valid up to ..... [Date] and if any further extension to this is required, the same will be extended on

receiving instruction from ----- on whose behalf this Bank Guarantee has been issued.

2. We, the \_\_\_\_\_ [indicate the name of the Bank, Address, Code] do hereby further undertake to pay the amounts due and payable under this guarantee without any demur, merely on a demand from OPTCL. Any such demand made on the Bank shall be conclusive as regards the amount due and payable by the Bank under this guarantee. However, our liability under this guarantee shall be restricted to an amount not exceeding Rs..... ( Rupees in words.....)
3. We undertake to pay to OPTCL any money so demanded not withstanding any dispute or disputes so raised by the bidder in any suit or proceeding instituted/pending before any court or tribunal relating thereto, our liability under this present being absolute and unequivocal. The payment so made by us under this bond shall be a valid discharge of our liability for payment thereunder and the bidder shall have no claim against us for making such payment.
4. We, the \_\_\_\_\_ Bank further agree that the guarantee herein contained shall remain in full force and effect during the aforesaid period of \_\_\_\_\_ days [in words]..... (as per Tender Specification) and it shall continue to be so enforceable till all the dues of OPTCL under or by virtue of the said Bid have been fully paid and its claims satisfied or discharged or till OPTCL certifies that the terms and conditions of the said Bid have been fully and properly carried out by the said bidder and accordingly discharges this guarantee. Unless a demand or claim under this guarantee is made on us or our Branch Office at Bhubaneswar <Mention Name, Address & Code of the Branch Office at Bhubaneswar of Issuing Bank> in writing on or before \_\_\_\_\_ we shall be discharged from all liability under this guarantee thereafter.
5. We the \_\_\_\_\_ Bank further agree with OPTCL that OPTCL shall have the fullest liberty without our consent and without affecting in any manner our obligations hereunder to vary any of the terms and conditions of the said Bid or to extend time of performance by the said Bidder from time to time or to postpone for any time or from time to time any of the powers exercisable by OPTCL against the said Bidder and to forbear or enforce any of the terms and conditions relating to the said Bid and we shall not be relieved from our liability by reason of any such variation, postponement or extension granted to the Bidder or for any forbearance, act or omission on the part of OPTCL or any indulgence by OPTCL to the said Bidder or by any such matter or thing whatsoever which under the law relating to sureties would, but for this provision, have the effect of so relieving us.
- 6 This guarantee will not be discharged due to the change in the name, style and constitution of the Bank and/or of the Bidder.
- 7 We \_\_\_\_\_ [indicate the name of Bank, Address &Code] lastly undertake not to revoke this guarantee during its currency except with the previous consent of OPTCL in writing
8. We, the \_\_\_\_\_ Bank (Name, Address & Code) further agree that this guarantee shall also be invocable at our place of business at ----- Branch of

**Bhubaneswar** (indicate Name, Address & Code of the Branch at Bhubaneswar) in the State of Odisha.”

**“ Notwithstanding anything contained herein”**

a) Our liability under the bank guarantee shall not exceed Rs.------(Rupees in words-----) only.

b) This Bank guarantee shall be valid up to -----.

c) We or our Branch at Bhubaneswar <Mention Name, Address & Code.....> shall be liable to pay guaranteed amount or any part thereof under this guarantee only if you serve upon us at----- Branch of Bhubaneswar a written claim or demand on or before .....,

The Bank Guarantee is issued in paper form and Advice transmitted through SFMS with required details to the beneficiary’s advising bank (ICICI Bank Bhubaneswar, IFSC Code ICIC0000061).

Dated, the \_\_\_\_\_ Day of \_\_\_\_\_

For \_\_\_\_\_ [Indicate name of Bank]

Signature .....  
Full name .....  
Designation .....  
Power of Attorney No. ....  
Date.....  
Seal of the Bank.....

**WITNESS: (SIGNATURE WITH NAME AND ADDRESS)**

(1)  
Signature .....  
Full name .....  
(2)  
Signature .....  
Full name .....

**N.B.:**

1. Name of the Bidder.: .....
2. BG No & Date :.....
3. Amount (In Rs.):.....



4. Validity up to :.....
5. E-NIT No.....
6. Package/Works No.....
7. Name, Address & Code of Issuing Bank:.....
8. Name, Address & Code Bhubaneswar Branch of the Issuing Bank:.....
9. The Bank Guarantee shall be accepted after getting SFMS advice as per details below.

### Format for SFMS details

**(The Unique Identifier for field 7037 is “OPTCL541405793”)**

Sl. No	PARTICULARS	TYPE	DETAILS
1	Type of Bank Guarantee	Mandatory	EMD
2	Currency & Amount	Mandatory	
3	Validity Period(from—to --)	Mandatory	
4	Effective Date	Mandatory	
5	End date of lodgment of Claim	Mandatory	
6	Place of lodgment of claim	Mandatory	Bhubaneswar, Branch Name----- of Bhubaneswar Branch code----- of Bhubaneswar Branch Address ----- at Bhubaneswar
7	Issuing Branch IFSC Code	Mandatory	
8	Issuing Branch name & address	Mandatory	
9	Name of applicant and its details	Mandatory	
10	Name of Beneficiary and its details	Mandatory	
11	Beneficiary’s Bank/Branch and IFSC Code	Mandatory	ICICI Bank Ltd IFSC Code-ICIC0000061

12	Beneficiary's Bank/Branch name and address	Mandatory	ICICI Bank Ltd Bhubaneswar Main Branch, Bhubaneswar
13	Sender to receiver information	Mandatory	
14	Purpose of Guarantee	Mandatory	EMD
15	Reference/Description of the underlined tender/contract	Mandatory	NIT No

ANNEXURE-VII

[PROFORMA FOR COMPOSITE BANK GUARANTEE FOR SECURITY DEPOSIT  
PAYMENT AND PERFORMANCE]

**(To be stamped in accordance with Stamp Act and the Non-Judicial stamp paper of appropriate value should be in the name of the Issuing Bank.)**

**Ref No:- .....**

**Bank Guarantee No. ....**

**Date: .....**

**BG Amount:.....**

**Validity Period:.....**

This Guarantee Bond is executed this..... day of ..... by us the..... Bank at ....., P.O....., Dist....., State..... and Code No.....

Whereas the ODISHA POWER TRANSMISSION CORPORATION Limited, Janpath, Bhubaneswar, a company constituted under the Companies Act-1956 (hereinafter called OPTCL) has issued Letter of Award (LOA) No..... Dated..... for the purpose of ..... work under Package No..... (herein after called "the Agreement") to M/s/Shri ....., Address..... (herein after called the "Contractor") for supply, erection, installation & commissioning and associated civil works under the above LoA and whereas OPTCL has agreed (1) to exempt demand of security deposit under the terms and conditions of the LOA (2) to release payment of the cost of the Contract Price to the Contractor on furnishing by the Contractor to OPTCL a Contract Performance Bank Guarantee (CPBG) of the value of 10% of the Contract Price of the said Agreement.

1. Now therefore, in accordance with the terms and conditions of LOA No. \_\_\_\_\_ dated \_\_\_\_\_ for the due fulfillment by the said Contractor of the terms and

conditions contained in the said agreement, on production of a Bank Guarantee for Rs. \_\_\_\_\_ (Rupees \_\_\_\_\_) only, we the bank \_\_\_\_\_ [Indicate bank Name , Address & Code ] (hereinafter referred to as “the Bank”) at the request of M/s/Shri \_\_\_\_\_ contractor do hereby undertake to pay to OPTCL, an amount not exceeding Rs. \_\_\_\_\_ (Rupees \_\_\_\_\_) only .

2. We, the \_\_\_\_\_ Bank [indicate the name of the Bank, Address & Code] do hereby undertake to pay the amounts due and payable under this guarantee without any demur, merely on a demand from OPTCL. Any such demand made on the bank shall be conclusive as regards the amount due and payable by the bank under this guarantee. However, our liability under this guarantee shall be restricted to an amount not exceeding Rs. \_\_\_\_\_ (Rupees----- In Words).

3. We, the ..... Bank also undertake to pay to OPTCL any money so demanded notwithstanding any dispute or disputes raised by the Contractor in any suit or proceeding instituted / pending before any court or tribunal relating thereto, our liability under this present being absolute and irrevocable. The payment so made by us under this bond shall be a valid discharge of our liability for payment thereunder and the Contractor shall have no claim against us for making such payment.

4. We, the \_\_\_\_\_ Bank further agree that the guarantee herein contained shall remain in full force and effect during the aforesaid period of \_\_\_\_\_ days and it shall continue to be so enforceable till all the dues of OPTCL under or by virtue of the said Agreement have been fully paid and its claims satisfied or discharged or till OPTCL certifies that the terms and conditions of the said Agreement have been fully and properly carried out by the said contractor and accordingly discharges this guarantee.

Unless a demand or claim under this guarantee is made on us or our Branch Office at Bhubaneswar <Mention Name, Address & Code of the Branch Office at Bhubaneswar of issuing Bank> in writing on or before ..... (Date), we shall be discharged from all liability under this guarantee thereafter.

5. We, the \_\_\_\_\_ Bank [indicate the name of the Bank, Address & Code] further agree with the Board that OPTCL shall have the fullest liberty without our consent and without affecting in any manner our obligations hereunder to vary any of the terms and conditions of the said Bid or to extend time or performance by the said contractor(s) from time to time or to postpone for any time or from time to time any of the powers exercisable by OPTCL against the said contractor(s) and to forbear or enforce any of the terms and conditions relating to the said Bid and we shall not be relieved from our liability by reason of any such variation postponement or extension being granted to the said contractor(s) or for any forbearance, act or omission on the part of OPTCL or any indulgence by OPTCL to the said contractor(s) or by any such matter or thing whatsoever which under the law relating to sureties would, but for this provision, have the effect of so relieving us.

6. This guarantee will not be discharged due to the change in the name, style or constitution of the Bank and/or of the contractor(s).

7. We, the \_\_\_\_\_ Bank [indicate the name of the bank, Address & Code ] lastly undertake not to revoke this guarantee during its currency except with the previous consent of OPTCL in writing.

8. We, the \_\_\_\_\_ Bank (Name, Address & Code) further agree that this guarantee shall also be invocable at our place of business at **Bhubaneswar** (indicate Name, Address & Code of the Branch at Bhubaneswar) in the State of Odisha.

**“ Notwithstanding anything contained herein”**

a) Our liability under the bank guarantee shall not exceed Rs.------(Rupees in words-----) only.

b) This Bank guarantee shall be valid up to -----.

c) We or our Branch at **Bhubaneswar** <Mention Name, Address & Code.....> shall be liable to pay guaranteed amount or any part thereof under this guarantee only if you serve upon us at----- Branch of Bhubaneswar a written claim or demand on or before .....,

The Bank Guarantee is issued in paper form and Advice transmitted through SFMS with required details to the beneficiary’s advising bank (**ICICI Bank Bhubaneswar**, IFSC Code ICIC0000061).

Dated, the \_\_\_\_\_ Day of \_\_\_\_\_  
For \_\_\_\_\_ [Indicate name of Bank]

Signature.....

Full Name.....

Designation.....

Power Of Attorney.....

Dated.....

Seal of the Bank.....

**WITNESS: (SIGNATURE WITH NAME AND ADDRESS)**

1. Signature.....

Full Name.....

2. Signature.....

Full Name.....

N.B.:

1. Name of the Contractor.: .....

2. BG No & Date :.....

3. Amount (In Rs.):.....
4. Validity up to :.....
5. LOA No.....
6. Package No.....
7. Name, Address & Code of Issuing Bank:.....
8. Name, Address & Code of Bhubaneswar Branch of the Issuing Bank:.....
10. The Bank Guarantee shall be accepted after getting SFMS advice as per details below.

### Format for SFMS details

**(The Unique Identifier for field 7037 is “OPTCL541405793”)**

Sl. No	PARTICULARS	TYPE	DETAILS
1	Type of Bank Guarantee	Mandatory	Contract Performance
2	Currency & Amount	Mandatory	
3	Validity Period(from—to --)	Mandatory	
4	Effective Date	Mandatory	
5	End date of lodgment of Claim	Mandatory	
6	Place of lodgment of claim	Mandatory	Bhubaneswar, Branch Name----- of Bhubaneswar Branch code----- of Bhubaneswar Branch Address ----- at Bhubaneswar
7	Issuing Branch IFSC Code	Mandatory	
8	Issuing Branch name & address	Mandatory	
9	Name of applicant and its details	Mandatory	
10	Name of Beneficiary and its details	Mandatory	
11	Beneficiary’s Bank/Branch and IFSC Code	Mandatory	ICICI Bank Ltd IFSC Code-ICIC0000061

12	Beneficiary's Bank/Branch name and address	Mandatory	ICICI Bank Ltd Bhubaneswar Main Branch, Bhubaneswar
13	Sender to receiver information	Mandatory	
14	Purpose of Guarantee	Mandatory	Contract Performance
15	Reference/Description of the underlined tender/contract	Mandatory	LOA No----

**N.B. : To be Stamped in accordance with Stamp Act and the Non-Judicial Stamp Paper of appropriate value should be in the name of Issuing Bank**

#### ANNEXURE-VIII

CHART SHOWING PARTICULARS OF EARNEST MONEY DEPOSIT FURNISHABLE BY TENDERERS

1.	Central and State Government Undertakings	Exempted
2.	All other inside & outside state units.	The amount of EMD as specified in the specification /Tender Notice in shape of bank guarantee /DD.

NB: - REFUND OF E.M.D.

- [a] In case of unsuccessful tenderers, the EMD will be refunded immediately after the tender is decided. In case of successful tenderer, this will be refunded only after furnishing of Composite Bank Guarantee referred to in clause No.19 of Section-II of this specification.

Suits, if any, arising out of EMD shall be filed in a court of law to which the jurisdiction of High Court of ODISHA extends.

- [b] Earnest Money will be forfeited if the tenderer fails to accept the letter of intent/purchase order, issued in his favour or revises the bid price[ s] within the validity period of Bid.

### **ANNEXURE-IX**

#### DATA ON EXPERIENCE

- [a] Name of the manufacturer.
- [b] Standing of the firm as manufacturer of equipment quoted.
- [c] Description of equipment similar to that quoted [supplied and installed during the last two years with the name of the organizations to whom supply was made].
- [d] Details as to where installed etc.
- [e] Testing facilities at manufacturer's works.
- [f] If the manufacturer is having collaboration with another firm, details regarding the same and present status.
- [g] A list of purchase orders, executed during last three years.
- [h] A list of similar equipments of specified MVA rating, voltage class, Impulse level, short circuit rating, Designed, manufactured, tested and commissioned which are in successful operation for at least two years from the date of commissioning with legible user's certificate. User's full complete postal address/fax/phone must be indicated. (Refer clause No.7 of the Part-I, Section-II of the specification).

Place:

Date:

Signature of Bidder

Name, Designation, Sea

### **ANNEXURE-X**

SCHEDULE OF SPARE PARTS FOR FIVE YEARS OF NORMAL OPERATION & MAINTENANCE

SL. No	Particulars	Quantity	Unit delivery rate	Total price

Place:

Date:

Signature of Bidder

Name, Designation, Seal

**ANNEXURE-XI**

**SCHEDULE OF INSTALLATIONS.**

Details of equipment, offered	Rated Voltage	Place of installation and complete postal address	Year of commissioning

Place: -

Date

Signature of Bidder:

Name, Designation, Seal

**ANNEXURE-XII**

**DEVIATION SCHEDULE**



**Bidder shall enter below particulars of his alternative proposal for deviation from the specification, if any.**

(To be filled up by the tenderer as indicated in the excel sheet)

**ANNEXURE - XIII**  
**LITIGATION HISTORY**

Name of the Bidder:

Bidder should provide information on any history of litigation or arbitration resulting from contracts executed in the last five years or currently under execution.

Year.	Award for or against bidder	Name of client, cause of litigation and matter in dispute	Disputed amount (current value in Rs.)

Place: -

Date

Signature of Bidder:

**ANNEXURE-XIV**

**Certificate ( to be furnished in bidder company’s letter head)**

I have read the clause regarding restrictions on procurement from a bidder of a country which shares a land border with India and on sub-contracting to contractors from such countries; I certify that this bidder is not from such a country or, if from such a country, has been registered with the Competent Authority and will not sub-contract any work to a contractor from such countries unless such contractor is registered with the Competent Authority. I hereby certify that this bidder fulfils all requirements in this regard and is eligible to be considered. [Where applicable evidence of valid registration by the Competent Authority shall be attached.]

Authorized signatory

Company seal

**ANNEXURE-XV**

**AFFIDAVIT OF BIDDER**

**(To be submitted in a non-judicial stamp paper of appropriate value)**

BEFORE Sri/ ....., Notary, At-.....  
.....

**Affidavit**

WHEREAS the Odisha Power Transmission Corporation Ltd., Bhubaneswar(OPTCL) has floated its Tender No.....inviting bids from eligible bidder to execute the work of.....

AND WHEREAS M/s ..... (Briefly "Bidder") has offered its bid on .....in response to the said Tender No.....of the OPTCL expressing its interest to execute the work as specified therein.

AND WHEREAS the said Tender No..... of OPTCL requires the Bidder to solemnly affirm the correctness of the document and information furnished in its bid, so offered to OPTCL.

NOW THEREFORE, in response to the requirement, the Tender No..... of OPTCL, and having been duly authorized by the Bidder, I Sri/ Mrs. .... aged about ..... years, Son/Daughter/Wife of Sri/Mrs. ...., At present working as..... of M/s..... (The Bidder) do hereby solemnly affirm and state as follows:

1. That I am competent and have been duly authorized by the Bidder M/s..... to swear this affidavit on its behalf.

2. That the documents and information furnished by the Bidder in its bid offered in respect to the said Tender No.....of OPTCL are true and correct.
3. That in the event any document and information as furnished by the Bidder in response to the said Tender No of OPTCL is found/ considered by the OPTCL at any time as to be not correct/ wrong, the OPTCL shall be competent and at liberty without any show cause to the Bidder to terminate its contract/ agreement With the Bidder, if any.
4. The OPTCL shall also be competent, without any reference to the Bidder, to black list the Bidder and debar the Bidder from participating in any other Tender of OPTCL pursuant to its consideration/ finding that the Bidder has furnished any incorrect/ wrong document and information tendered/made pursuant to Tender No of OPTCL.
5. That the affirmation made herein above is/are correct and true and nothing Stated herein is false.

Identified by  
**DEPONENT**

**ADVOCATE**

# **SECTION – IV**

## **LOT-I**

### **TECHNICAL SPECIFICATION FOR 220 VOLTS VENTED LEAD ACID STORAGE BATTERY (PLANTE TYPE).**

#### **1. IMPORTANT INSTRUCTION:**

**Please read the following instructions carefully before submitting your bid:**

- 1.1. All the drawings, i.e. dimension, elevation, side view, front view, plan, cross sectional view, isometric view, important component drawing etc., in PDF along with AutoCAD format and manuals (Technical/Installation/Operation) in PDF format, for offered item shall be submitted. The hard copies as per specification also shall be submitted.
- 1.2. The acceptability of Type Test reports submitted by any bidder/EPC shall be strictly in adherence to the broad guidelines mentioned in clause no. 2 of “CEA guidelines for the validity period of Type Tests conducted on major electrical equipment of power transmission system” published in May 2020.
- 1.3. The Bidder/EPC shall have to submit all the required type test reports for the offered item along with the accessories. In case of submission of soft copy of type test report, high resolution colour scan of the original test report must be submitted. Scanned copy of Xerox of type test reports shall not be entertained. If required, the firm has to show the original type test report for the purpose of verification. In absence of this, the evaluation shall be carried out accordingly as non-submission of type test reports. The type test report of 220 volt DC Battery submitted by the manufacturer shall be considered valid if the date of type test does not exceed 07 years as on the last date of submission of bid; provided:-

There is no major changes introduced in the basic design / technology /material /mechanical /construction /functionalities /performance characteristics/ manufacturing process of the equipment.

**OR**

Until the relevant IS/IEC / statutory guidelines is revised which warrants fresh type tests because of introduction of new type tests even though there is no change in material/basic design of the equipment.

- 1.4. The Bidder/EPC must fill up all the point of GTP for offered item/s. Instead of indicating “refer drawing, or as per IS/IEC”, the exact value/s must be filled in. All the points other than GTP, which are asked to confirm in technical specifications must be submitted separately with the bid.
- 1.5. The Bidder/EPC is required to impart training in view of manufacture, assembly, erection, operation and maintenance for offered item, at his works, to the person/s identified by

OPTCL, in the event of an order, free of cost. The cost of logistics will be borne as per the clauses of respective purchase orders/work orders.

- 1.6. The discrepancies between the specification and the catalogues or literature, submitted as part of the offer OR with prevalent standards/Govt. guidelines shall not be considered as valid deviations unless otherwise the same deviations related to TS is brought out separately by the Bidder/EPC in the pre-bid queries or in form of clarification. If any modification felt necessary to improve performance, efficiency and utility of equipment, the same must be submitted along with Pre-Bid Queries with reasons duly supported by documentary evidences and such modifications, not mentioned in Pre-bid queries, will not be considered.
- 1.7. For purpose of Agreement, the firm shall provide warranty as specified in the purchase order / tender document. Notwithstanding the foregoing, Supplier agrees to waive the expiration of the Warranty Period in the event where in a pattern of defect/trend of failure is observed after the Warranty Period in a significant portion of the supplied quantity, or any critical defect discovered which, in Purchaser's opinion, constitutes a threat of damage to property or to the health and safety of any person.
- 1.8. Warranty certificate for purchase of any material, whether directly procured by OPTCL or EPC agency, shall be issued directly in favour of OPTCL.

## 2. SCOPE:

- 2.1. These specifications cover the design, manufacturer, assembly, shop testing at manufacturer's works before dispatch, supply and delivery at SITE and erection, testing and commissioning of 220 volt vented lead Acid storage Battery.
- 2.2. The scope of supply shall include all parts and accessories etc. which are usual and necessary for erection, operation and maintenance of the battery banks and the chargers, as specified, above though not individually and specifically stated or enumerated.
- 2.3. This scope shall also include the lifting of old batteries on buy back system basis if mentioned in the purchase order/work order.

## 3. STANDARDS:

- 3.1. The equipment shall comply in all respects with the latest edition of relevant Indian Standard & IEC Specifications except for the modifications specified herein. The equipment manufactured according to any other authoritative national / international standard which ensure an equal or better quality than the provisions of these specifications shall also be acceptable. Where the equipment offered conform to any other standard, salient points of differences between the proposed standard and the provisions of these specifications shall be clearly brought out in the tender. A Xerox copy of such standards [in English shall be enclosed with the offer].

### 3.2. LIST OF RELEVANT STANDARDS IS BS/IEC GIVEN BELOW :

A	Indian Standards	
1	IS:1885-15	Electro technical Vocabulary, Part 15: Primary Cells and Batteries

2	IS1652	Stationary cells and lead-acid type with batteries, Planté positive plates
3	IS 266	Sulphuric acid
4	IS 1069	Quality Tolerances for Water for Storage Batteries
5	IS 6071	Synthetic separators for lead-acid batteries
6	IS 3116	Sealing Compound for Lead-acid Batteries (Bitumen Based)
7	IS 1146	Rubber and plastic containers for lead-acid storage batteries
8	IS 8320	General Requirements and Methods of Tests for Lead-acid Storage Batteries
<b>B</b>	<b>IEC Standards</b>	
1	IEC 60896-11	Stationary lead-acid batteries – Vented types – General requirements and methods of tests
2	IEC 62485-1	Safety Requirements for Secondary batteries and Battery Installations – General Safety Information
3	IEC 62485-2	Safety Requirements for Secondary batteries and Battery Installations – Stationary Batteries
<b>C</b>	<b>ANSI/IEEE Standards</b>	
1	IEEE Std 484	IEEE Recommended Practice for Installation Design and Installation of Large Lead Storage Batteries for Generating Stations and Sub-stations
2	IEEE Std 485	IEEE Recommended Practice for Sizing Lead-Acid Batteries for Stationary Applications
<b>D</b>	<b>Other Standards</b>	
1	DIN 40738	Lead storage batteries; stationary cells with positive Planté plates, narrow plate distance; rated capacities, main dimensions
2	BS 6290-2	Lead acid stationary cells and batteries – Specification for the high-performance Plante positive type

**4. PARTICULARS OF THE SYSTEM:**

**4.1** One set of 220 Volts, 350AH Vented capacity battery along with equipment such as boost charger, trickle charger shall be sufficient to cater to the DC power requirements in different EHT Sub-stations in the State under OPTCL. DC System shall have rated nominal voltage of 220 V designed for maximum durability during all service condition including high rate of discharge and rapid fluctuation of load.

**4.2** The battery set(s) are meant to cater the following DC load requirements under emergency conditions without any assistance from chargers:

Continuous Loads	Emergency DC Lighting, Protection Panels (Relays, IEDs, Indicating lamps, Annunciators etc.), SAS System, Station HMIs, Inverters, LT DC System, Miscellaneous permanently connected loads etc.
Non-continuous Loads	CB Spring Charging Motor, Isolator/Earth Switch Operation Motor in GIS etc.
Momentary loads	Simultaneous CB Tripping etc.
Random Loads	Loads that occur at random should be shown at the most critical time of the duty cycle in order to simulate the worst-case load on the battery.

## 5. GENERAL REQUIREMENTS OF THE EQUIPMENT:

General requirement of the different components of the Battery system are given below.

- 5.1** One set of 220V, 350AH vented lead acid type having high cyclability, Low maintenance storage battery set is for required for meeting the D.C. load requirements of E.H.V sub-station for indicating lamps, emergency lighting, relays, alarms, circuits breakers etc. of normal load current of 10 Amp.(max) and maximum intermittent load of 45 Amps.
- 5.2** The battery shall be kept in healthy conditions with the help of the existing float charging unit. The existing boost charger unit shall supply quick charging current to bring back the battery to fully charged conditions after it has discharged to a considerable extent while meeting the emergency load. The battery shall meet practically all the heavy current demands, as required for operation [closing and / or opening of circuit breakers, emergency lighting load etc. It should be noted that, the 220V batteries are to be accommodated within the floor space area and area to be provided by the manufacturer in the following format.

SL.NO	PARTICULARS	ROOM SIZE
1	350 AH 220 VOLT SINGLE SET	
2	350 AH 220 VOLT DOUBLE SET	

- 5.3** It should operate satisfactorily over the entire range of ambient temperature of 0° C to 50° C and relative humidity of 95%.

## 6. DETAILS OF SPECIFICATIONS OF VENTED LEAD ACID BATTERIES:

- 6.1** The batteries shall be made of closed type lead acid cells of very low internal resistance having high cycling capability ,moderate size, high service life minimum 25 years, excellent performance for both low & high rates of discharge, rigid cell plates design type manufactured to conform to relevant latest IS/IEC.

### **6.2 CAPACITY:**

The capacity of the batteries shall be as follows:

- i. Voltage. - 220V
- ii. Output at 27° C- 350AH at 10 hrs. Discharge rate.

The batteries shall normally remain under 'floating' condition with the 'trickle' charger supplying the continuous load. However, the batteries shall be capable of supplying the following loads under emergency conditions without any assistance from the chargers and without their terminal voltage falling below 198 V [90% of rated voltage]

- i. I stage [continuous] - 35A for 10 hours.
- ii. II Stage [emergency] - continuous current of 35 Amps. Plus light load of 10 Amps

- 6.3** **The Battery Bank shall consist of 110 Nos. battery cells with 2 Volt nominal voltage per cell and for the minimum [discharged condition] voltage of the cells, the voltage of the battery set not be less than 85% of the rated voltage (220 Volt), while the assigned rating of the battery bank cannot be less than its rated voltage of 220 volts.**

## 7. DESIGN AND CONSTRUCTION DETAILS:

**7.1. Containers :** The containers for the cells shall be of high grade, impervious molded transparent, with excellent thermal, chemical & impact resistance having heat-resisting, high strength, non-reacting, halogen free Styrene-Acrylonitrile (SAN) and low inflammable properties conforming to latest IS/IEC. The containers shall be mounted on insulators blocks. The containers shall be of robust construction and free from flaws, bubbles or foreign matter. The surface of the containers shall have a finish substantially free from blisters, rough spots, scales, blow holes and other imperfections or deformations. The handle bars, if provided, shall be of such that sufficient sediment space shall be available and the batteries will not have to be cleared out during their normal life. Battery containers shall be subjected to type, Routine and Acceptance Tests as per the requirements of IS/IEC latest edition. The containers of the label attached firmly to the containers shall be marked with the information as per requirements of cl No. 2.2 of the above standard. The supplier's manufacturer's test certificates shall be submitted by the Bidder for the scrutiny of the purchaser.

### 7.2. PLATES :

- (a) POSITIVE PLATES :** The positive plates shall be of pure lead. Structure made by pasting of active materials is not acceptable. It shall offer high resistance to corrosion. The plates shall be arranged in hanging/any other position inside the container, which will allow the growth extending superior ageing of the battery.
- (b) NEGATIVE PLATES :** The negative plates shall be pasted antimonial-lead/lead alloy Grid plate type so designed as to hold the active material securely in place and in firm contact with the grid during service. The plates shall be designed for maximum durability and shall not buckle during all service conditions including high rate of discharge and the fluctuation of load.

**7.3. Separators:** The micro porous combined with pocket for positive plates separators shall be of synthetic material conforming to the latest edition of IS/IEC. These shall permit free flow of electrolyte and would not be affected by the chemical reaction inside the cell and shall last for indefinite time. The internal resistance factor of the separators shall assure high discharge characteristics under all operating conditions. Proper arrangement to keep end plates in position shall be furnished by the bidder along with his offer.

**7.4. Electrolyte:** The electrolyte (dilute sulphuric acid) shall be prepared from the battery grade sulphuric acid conforming to IS-266-1993 and shall have a specific gravity of 1.2 at 270C. The sulphuric acid of battery grade shall be colorless liquid. The concentrated sulphuric acid on dilution with an equal volume of distilled water shall be free from suspended matter and other visible impurities. The sulphuric acid shall meet the requirements of columns – 4 and 5 Table –1 of IS-266-1993. The requisite quantity shall be despatched in non-returnable containers suitably packed and marked as per the requirements of the above Indian Standards. The container materials and packing shall be subject to approval of the purchaser. Sufficient quantity of distilled water conforming to IS-1069-1993 shall be supplied in non-returnable containers to correct the level of electrolyte during initial testing and



commissioning. The material of containers and packing shall be subject to the approval of the purchaser.

7.5. Plate group bar with terminals: The plate group bar with terminals shall conform to latest IS/IEC.

(a) Terminal: Leak proof safety pole with solid brass/lead insert & M10 stainless steel bolt. The nuts & Bolts should be of same materials.

(b) Connectors: Insulated solid copper/lead connectors shall be used.

The positive and negative terminals shall be clearly marked for easy identification. The legs of the plates of like polarity shall be connected to the load, turned to a horizontal group bar having an upstanding terminal post adopted for connection to the external circuit. The group bars shall be sufficiently strong to hold the plates in position.

7.6. **Buffers/spring:** Suitable buffers / springs shall be provided in the cells to keep the end plates in position. These shall have adequate length and strength.

7.7. **Cell lids:** Lids used with sealed or closed type cells shall be of glass, plastic or ebonite and shall be provided with vent plugs. Terminal post shall be suitably sealed at the lid to prevent escape of acid spray, by means of rubber grommets, sealing compound or other suitable device. The positive and negative terminal posts shall be clearly and indelibly marked for easy identification.

7.8. **Water:** - Water used for preparation of electrolyte and also to bring the level of electrolyte to approximately correct height during operation / testing shall conform to relevant standards.

7.9. **Venting device :** The venting device(vent pug) shall be anti-splash, flame arrestor type and shall allow gases to escape freely but shall effectively prevent acid particles or spray from coming out. The length of insertion of vent pug shall be so arranged that will give high conductivity. Vent plug shall be maintenance free over entire service life. The safety vent plug shall have excellent gas drying properties, prevents emission of electrolyte or aerosols. It should be easily remove for cell inspection. There shall be two vent holes, one serving as a guide for acid level indicator for checking the electrolyte level and other to permit drawing of electrolyte samples, servicing, checking of specific gravity etc.

7.10. **Marking:** Acid level line shall be permanently and indelibly marked around on all the containers with maximum & minimum.

The following information shall be indelibly marked on the outside surface of each cell:

- a. Manufacturer's name, type and trade mark.
- b. Nominal voltage.
- c. AH capacity at 10 hours rate with specified end cell voltage.
- d. Cell number.
- e. Upper and lower electrolyte level in case of transparent containers.
- f. Type of positive plate.
- g. Type of container.
- h. Date of manufacture [month and year] or [week and year].

## **8. INSTALLATION OF BATTERY:**

- 8.1. Battery shall be installed on FRP coated steel/seasoned wood racks in a non-air-conditioned ventilated battery room. The Bidder shall offer racks and mounting insulators etc.
- 8.2. Cell shall be arranged on the racks in a two-tier arrangement with two rows of cells on each tier or with some other suitable arrangement depending upon the availability of space inside the battery room. The lay out shall be subject to the approval of the purchaser. The wooden racks shall be constructed of best quality seasoned wood with at least three [3] coats of anti-acid paint of approved shade and also flame proof coating. Stand should have at least 5.0 mm FRP coating and the FRP coated shall be non-reactant to acid. The stand should be suitable for mounting on flat concrete floor & should be designed to withstand loading of the Battery set throughout its life. These racks shall be such that cells are located at convenient height to facilitate maintenance and they may be so constructed so as to promote free access to the floor directly beneath the rack to facilitate easy cleaning of the floor. These shall be designed and arranged in such a way that easy handling of the cells is possible while in operation. Numbering tags for each cell shall be attached on to the racks.
- 8.3. Bidder shall indicate and include the proposed arrangement of the batteries and include arrangement for fixing and mounting of inter-bank, inter-row, inter-cell and tap-off connectors etc.

## **9. CONNECTORS-**

Solid copper/ lead connectors with transparent cap for ease of inspection shall be employed for Inter-cell and inter-row, inter-tier connections. Possibility of voltage check through an opening of small size for allowing the pin of the lead of the millimeter can be inserted in the cap. However, the tee-off connection from the battery unit shall be made with acid resisting cables of suitable size. A suitable terminal box along with acid-resisting cable shall be provided by the Bidder for this purpose. The connectors shall preferably be of bolted type and the bolts and nuts shall be of similar material as that of connectors and shall be provided with corrosion resisting lead coating.

The connectors shall be of sufficient cross-section to withstand all the working conditions including one minute discharge rate as well as short circuit conditions.

## **10. ACCESSORIES**

The equipment and accessories, listed below shall be furnished as part of each battery and the price of the battery quoted shall be inclusive of these items.

- I. FRP racks / Teak Wood racks with three coats of anti-acid paint and flame-proof coating.
- II. Stand insulators (+20% extra.)
- III. Cell insulators (+5% extra.)
- IV. All Cell inter-connectors and end take-offs.
- V. Lead coated connection hardware such as bolts, nuts etc.5% extra.
- VI. Cell numbering tags with fixing arrangement.
- VII. Cable clamps with hardware.

- VIII. Diluted sulphuric acid of required quantity and of specific gravity according to the relevant ISS and 10% extra shall be supplied in non-returnable acid proof containers, suitable packed.
- IX. Two number syringe type hydrometer complete with accessories and suitable for measuring SP gravity between 1.1 to 1.320 with graduation of 0.005 Sp. Gravity together with temperature correction charts.
- X. Two number floating hydrometer.
- XI. Two numbers thermo-meters having range 0-100 deg. C whose one division of the graduated scale shall represent at the most 1 degree centigrade with separate gravity correction chart.  
[Accuracy of calibration shall not be less than 0.50C]
- XII. One number wall mounting teak-wood for hydrometers and thermo-meters.
- XIII. Two numbers acid-resisting plastic jugs [2 liter capacity]
- XIV. Two numbers plastic funnels.
- XV. Two numbers rubber syphon.
- XVI. Two numbers rubber aprons.
- XVII. Two pairs of rubber gloves.
- XVIII. Two pairs of rubber boots-knee height.
- XIX. Two sets special tools or tools required for connecting the terminals of the batteries.
- XX. The battery terminals shall be brought out in a junction box to be mounted on the battery stands.
- XXI. Ampere-hour meter [10 hour discharge rate] of 600 –1250 AH range-1 no.
- XXII. Any other accessories, not specified but required for installation, satisfactory operation and maintenance of batteries for a period of 5 [five] years.

#### **11. MAXIMUM SHORT CIRCUIT CURRENT :**

The Bidder shall state the maximum short circuit current of each battery along with the safe duration in seconds which it can withstand. Methods, proposed to be adopted for protecting batteries from the short circuit conditions should also be stated to avoid damage to the battery and loss to the associated equipment.

#### **12. VENTILATION:**

The bidder shall indicate in his bid the requirements of ventilation in the battery room. The battery shall operate satisfactorily over the entire range of the temperature and humidity indicted in this specification without affecting its normal life. Bidder shall indicate the percentage reduction in battery capacity at the lowest temperature of 27 deg C. If any special ventilation requirements are necessary, the same shall be indicated.

#### **13. CAPACITY:**

The standard Ampere-hour capacity at ten hour rate shall be 350 AH with an end cell voltage of 1.85 volts/cell.

#### **14. CHARGING:**

The bidders shall state whether an equalizing charge is recommended for the battery. If so, the equalizing charge voltage, current, duration and the interval between the equalizing charging

shall be specified in the Data sheet. Bidder shall also indicate the requirements for boost charging. The trickle charge current should also be specified.

**15. LIFE:**

The bidder shall quote in his offer the guaranteed life of the battery when operating under the conditions specified. As per clause A 5.1 the bidder shall also furnish the life cycle of the battery indicating the capacity of the battery each year upto 20 years in a tabular form & also in a graphical form in standard operating condition.

**16. INSTRUCTION MANUALS:**

Eight sets of instruction manuals for installation, commissioning, charging and maintenance instruction along with its soft copies in CD/DVDs shall have to be furnished

**17. TRANSPORT:**

The batteries, accessories and racks etc. shall be suitably packed and transported to site.

**18. TESTS:**

**18.1. Type Test:**

Along with their offer, the bidder/during submission of drawings, EPC shall submit type test reports of **all type tests as per IS 1652:1991 (or its latest revised edition) and other relevant/applicable National Standard[s]** conducted on the offered design, within seven years from the date of opening of the bid. The type tests should be conducted in a NABL accredited laboratory and the tests should have been witnessed by representatives of any Government Department / Government Undertaking, failing which the offer is liable for rejection/ failing which the drawings shall not be considered for approval.

If the type test report[s] does/do not meet the requirements as per this specification, OPTCL at its discretion may ask the supplier to conduct the above type test[s] at the supplier's cost in the presence of OPTCL's representative without any financial liability to OPTCL.

**18.2. Acceptance tests:**

**All factory acceptance tests (FAT) as per IS 1652:1991 (or its latest revised edition/amendments)** shall be witnessed by the OPTCL's representative at the works of the manufacturer at the cost of supplier.

For sampling of cells during FAT for 350 AH batteries, Annexure D of IS 8320:2000 (or its latest revised edition/amendments) shall be followed.

The manufacturer shall provide the test certificates (Type, Routine and Acceptance test) pertaining to **Battery Cell Containers** to OPTCL inspector at the time of acceptance test in accordance to IS 1146 (1986 or its latest revision / amendment.)

## 19. DRAWINGS / DOCUMENTS:

19.1. The Bidder shall submit the following drawings / documents along with his offer failing which the offer is liable for rejection.

- a. General battery arrangement, proposed size of individual and over all dimensions along with sectional views showing all connections etc.
- b. Pamphlets and technical literature giving detailed information of the batteries offered.

19.2. The manufacturer shall submit the following drawings / documents in 7 [seven] copies within 15[fifteen] days from the date of issue of the purchase order for purchaser's approval. :-

- i. Lay out details of the batteries.
- ii. OGA and cross-sectional details for battery cells.
- iii. Instruction manuals for initial charging and subsequent charging.
- iv. Technical data, curves etc.
- v. **Manufacturing Quality Plan of 220 Volt DC Battery.**

## 20. BUY- BACK OF OLD BATTERY CELLS:

The Bidder will quote buy-back rates of old battery cells (different AH capacities), available at the following Sub-Station of OPTCL in the State of Odisha. The scope of 'BUY-BACK' system includes the loading, transportation, taxes, duties, and any other statutory levies, rules and regulations, notified by Govt. of India/ Govt. of Orissa, or their Undertakings.

### OLD BATTERY SET FOR DISPOSAL ON BUY BACK:

#### DETAILS OF READILY AVAILABLE SCRAP (PHASE-I)/ WILL BE AVAILABLE AFTER BATTERY REPLACEMENT (PHASE-II)

PHASE	Sl. No.	Name of the Grid S/s	Make	Type	Rating	No. of cells in each set
I	1	Tusura	Exide	YKP-29	350AH	110
II	1	Rairangpur	Exide	YKP-29	350AH	110
	2	Jharsuguda	Exide	YKP-29	350AH	110
	3	Budhipadar	Exide	YKP-29	350AH	110
	4	Dhenkanal	Exide	YKP-29	350AH	110
	5	Kamakhyanagar	Exide	YKP-29	350AH	110
	6	Khajurikata	Exide	YKP-29	350AH	110
	7	Theruvai	Exide	YKP-29	350AH	109
	8	Akhusing	Exide	YKP-29	350AH	110
	9	Balasore	Exide	YKP-29	350AH	110
	10	Bhadrak	Exide	YKP-29	350AH	110
	11	Pattamundai	Exide	YKP-19	225AH	110

*The bidders are advised to inspect the old batteries, available in different Grid Sub stations prior to submission of their bids and the rate of the battery cell should be quoted in the prescribed price bid*

of this tender specification on AH basis. The bidder may also visit other Sub-stations of OPTCL and may quote for available Nos. of old battery cells on AH basis, stating the name of Sub-station, AH capacity of the cell, Nos. of cells etc. The old battery cells will be lifted by the bidder “AS IS WHERE IS BASIS” and the loading, transportation, taxes, duties and all other charges shall be borne by the Bidder. It should be noted that the bidder is to abide by all the rules, regulations, as prescribed by Govt. of India/Govt. of Odisha in this respect.

The purchaser may at its discretion may postpone/terminate the ‘BUY BACK OF OLD BATTERY CELLS, as the situation warrants or direct the bidder to lift old battery cells of similar type from other Grid Sub-stations or reduce the quantity of battery cells, to be sold on buy back system or free to the take any other decision, conducive to both the purchaser and the bidder.

**A.22. All deviations from the specification shall be separately listed, in the absence of which it will be presumed that the provisions of these specifications are complied with by the bidder.**

**ANNEXURE – I**  
**SCHEDULE OF GUARANTEED TECHNICAL PARTICULARS**  
**FOR 220V VENTED LEAD ACID STORAGE BATTERY( PLANTE TYPE)**  
 [To be filled in by the bidder]

Values/Others

1.	Manufacturer’s Name and address along with Fax No. & Tele phone No.	
2.	Conforming to standards	
3.	Type and designation as per ISS	
4.	Manufacturer’s type and designation	
5.	AH capacity and voltage of the battery at 27 deg.C.	
[a]	At 10 hour rate of discharge.	
[b]	At 5 hours rate of discharge.	
[c]	At 1 hour rate of discharge	
[d]	At 1 minute rate of discharge.	
[e]	At ½ hour rate of discharge.	
6.	Open circuit voltage of each battery cell.	
[a]	Fully charged	
[b]	Floating condition.	
[c]	When completely discharged at.	
[i].	10hr. rate.	
[ii].	5 hour rate	
[iii]	1 hour rate	
[iv]	½ hr. rate	
[v].	1 minute rate	
[vi]	1-second rate.	
7.	Recommended float charging voltage [volts] across the battery terminals.	
8.	Recommended boost charging voltage [volts].	

9.	Time required for boost charging from discharged conditions [in hours]	
10.	Trickle charging Current range/cell	
11.	AH capacity at 10 hour rate at 10 hour rate at room temperatures of :	
[a]	15 deg C.	
[b]	27 deg C.	
[c]	50 deg C.	
12.	CELL DETAILS	
[i].	No. of cells per Battery Bank	
[ii].	Total nos. of plates per cell.	
[iii]	No. of positive plates per cell.	
(iv)	Type of positive plate	
(v)	No. of negative plates per cell	
(vi)	Type of negative plate	
(vii)	Surface area of plates in sq. mm.	
(viii)	CONSTRUCTIONAL DETAILS AND DIMENSIONS OF	
(a)	Positive plate	
(b)	Negative plate	
(c)	Material of the container	
(d)	Thickness of the container	
(e)	Overall dimensions of each cell (LxBxH)	
ix.	Weight per Cell (Kg)	
(a)	Active elements-positive	
(b)	Active elements-Negative	
(c)	Container	
(d)	Net dry weight	
(e)	Weight with electrolyte	
x.	Distance between center of cells where erected.	
xi.	Nominal cell voltage.	
xii.	Internal resistance of each cell at	
(a)	Fully charged condition	
(b)	Fully discharged condition	
(c)	Floating condition	
13.	Type, Thickness and materials of the separators	
14.	Containers	

(a)	Type	
(b)	Material	
(c)	Outside dimensions (LxBxH)	
15.	Cover and its type and material	
16.	Clearance in mm between	
(a)	Top of plates and top of container	
(b)	Bottom of plates and bottom of container	
(c)	Edges of plates and inner surface of container.	
17.	Sediment space (depth) in mm	
18.	ELECTROLYTE	
(a)	Amount of electrolyte and specific gravity at 27 deg. C for first filling.	
(b)	First filling per set with 10% of extra furnished.	
(c)	Electrolyte conforms to standard	
(d)	Rated specific gravity of electrolyte when fully charged at room's temperature of	
(i)	15 deg. C	
(ii)	27 deg. C	
(iii)	50 deg C.	
(e)	Specific gravity of electrolyte at the end of discharge at 10 hour discharge rate.	
(f)	Maximum electrolyte temp. that the cells can withstand without injurious effect.	
(i)	Continuously	
(ii)	For short period	
19.	INTER CELL CONNECTOR	
(a)	Whether Inter-cell connector to be furnished ? (Yes / No)	
(b)	Type of inter-cell connector (bolted or others)	
(c)	Materials of inter cell connector	
20. (a)	Inter row, inter-tier connectors and end take-off furnished ? (Yes / No)	
(b)	Description, size, current rating, type and material.	
21.	RACKS	
(a)	No. of racks per battery	
(b)	No. of cells per rack	



(c)	Type of racks (rows and tiers)	
(d)	Material of the rack	
(e)	Racks provided with	
(i)	Numbering tags for cell	
(ii)	Teak wood clamps for cables	
(f)	Whether anti-acid coating provided ?	
(g)	Description of rack insulators	
(h)	Outline dimensions of racks	
(i)	Net weight of racks	
(j)	Shipping weight	
22.	Recommended rate for charging the battery in 8 hours.	Start Finish
(a)	Current	
(b)	Voltage	
23.	Recommended float charge rate	
24.	Resistance of the battery including inter-connector between the cells in ohms.	
25. (a)	Maximum short circuit current per battery	
(b)	Allowable duration of short circuit	
26.	Short circuit current for a dead short across the battery terminals when	
(a)	Float at 2.1 volts per cell.	
(b)	Boost charge to 2.75 volts per cell.	
27.(a)	Time to full charge at finishing rate only	
(b)	Time to full charge at higher starting rate	
(c)	Time for full charge to charge by two step charging at starting up and finishing rates	
28.	Guaranteed AH efficiency at 10 hour rate of discharge in percent.	
29.	Guaranteed WH efficiency at 10 hour rate of discharge in percent.	
30.	Instructions for filling and initial charging of the battery with finishing and two step charging rates.	
31.	Recommended interval at which battery should be discharged at 10 hour rate and quick charged.	
32.	Recommended floating voltage per cell and the minimum variation.	
33.	Recommended maximum period of storage before the first charge.	

34	Average life in years	
35.	Guaranteed life of battery in years.	
36.	Estimated life of battery in years.	
37.	Total shipping weight of battery units	
38.	Battery sizing calculation provided(Yes/NO)	
39.	Dimensioned lay-out drawings of the rack and battery to be attached with the tender. (Whether furnished ? Yes / No)	
40.	The following characteristic curves, to be furnished alongwith the tender (whether furnished)	
(a)	Battery discharge curves at various rates between one minute and 10 hour rate. (Yes / No.)	
(b)	Curves showing the relation between the specific gravity and amount of charge in the battery for both charging and discharging conditions. (Yes / No)	
(c)	Curves showing the relation between cell voltage and charging current when charged at	
(i)	Finishing rate (Yes/ No)	
(ii)	High starting rate (Yes/ No)	
(iii)	Two step charging by starting and finishing rate (Yes / No)	
(d)	Curve of internal resistance at the end of various discharge rates (Whether furnished (Yes / No)	

## **LOT – II**

# **BATTERY CHARGER (THYRISTOR CONTROL) WITH DROPPER DIODE SUITABLE FOR 220 VOLTS, 350AH VENTED LEAD ACID STORAGE BATTERY (PLANTE TYPE)**

## **1. IMPORTANT INSTRUCTION:**

**Please read the following instructions carefully before submitting your bid:**

- 1.1** All the drawings, i.e. dimension, elevation, side view, front view, plan, cross sectional view, isometric view, important component drawing etc., in PDF along with AutoCAD format and manuals (Technical/Installation/Operation) in PDF format, for offered item shall be submitted. The hard copies as per specification also shall be submitted.
- 1.2** The acceptability of Type Test reports submitted by any bidder/EPC shall be strictly in adherence to the broad guidelines mentioned in clause no. 2 of “CEA guidelines for the validity period of Type Tests conducted on major electrical equipment of power transmission system” published in May 2020.
- 1.3** The Bidder/EPC shall have to submit all the required type test reports for the offered item along with the accessories. In case of submission of soft copy of type test report, high resolution colour scan of the original test report must be submitted. Scanned copy of Xerox of type test reports shall not be entertained. If required, the firm has to show the original type test report for the purpose of verification. In absence of this, the evaluation shall be carried out accordingly as non-submission of type test reports. The type test report of Battery Charger submitted by the manufacturer shall be considered valid if the date of type test does not exceed 07 years as on the last date of submission of bid; provided:-  
There is no major changes introduced in the basic design / technology /material /mechanical /construction /functionalities /performance characteristics/ manufacturing process of the equipment.

**OR**

Until the relevant IS/IEC / statutory guidelines is revised which warrants fresh type tests because of introduction of new type tests even though there is no change in material/basic design of the equipment.

- 1.4** The Bidder/EPC must fill up all the point of GTP for offered item/s. Instead of indicating “refer drawing, or as per IS/IEC”, the exact value/s must be filled in. All the points other than GTP, which are asked to confirm in technical specifications must be submitted separately with the bid.
- 1.5** The Bidder/EPC is required to impart training in view of manufacture, assembly, erection, operation and maintenance for offered item, at his works, to the person/s identified by OPTCL, in the event of an order, free of cost. The cost of logistics will be borne as per the clauses of respective purchase orders/work orders.
- 1.6** The discrepancies between the specification and the catalogues or literature, submitted as part of the offer OR with prevalent standards/Govt. guidelines shall not be considered as valid deviations unless otherwise the same deviations related to TS is brought out separately by the

Bidder/EPC in the pre-bid queries or in form of clarification. If any modification felt necessary to improve performance, efficiency and utility of equipment, the same must be submitted along with Pre-Bid Queries with reasons duly supported by documentary evidences and such modifications, not mentioned in Pre-bid queries, will not be considered.

- 1.7 For purpose of Agreement, the firm shall provide warranty as specified in the purchase order / tender document. Notwithstanding the foregoing, Supplier agrees to waive the expiration of the Warranty Period in the event where in a pattern of defect/trend of failure is observed after the Warranty Period in a significant portion of the supplied quantity, or any critical defect discovered which, in Purchaser's opinion, constitutes a threat of damage to property or to the health and safety of any person.
- 1.8 Warranty certificate for purchase of any material, whether directly procured by OPTCL or EPC agency, shall be issued directly in favour of OPTCL.

**2. SCOPE:**

2.1 This Specification covers design, manufacture, inspection and testing before dispatch, packing and delivery F.O.R. (destinations) and installation of Battery Chargers with provision of Float and Boost charging for 220V 350 AH batteries consisting of 110 Nos., 2.0 Volts Lead Acid battery set, supply of spares and other accessories as specified here in. **This scope includes SCADA compatibility of Battery chargers to be supplied.**

2.2 Following is the list of documents constituting this Specification. :

(i)	Technical Specification (TS)	-
(ii)	Technical Requirements	Appendix-I
(iii)	Type test procedure for battery charger	Appendix-II
(iv)	Guaranteed Technical Particulars	Annexure-A
(v)	Delivery schedule	Annexure-B
(vi)	Calibration Status of testing equipment and meters/Instruments.	Annexure-C
(vii)	Check-list towards Type Test Reports.	Annexure-D
<b>Note: Annexure-A, B, C &amp; D are to be filled up by the Bidder/EPC.</b>		

- 2.3 All the above along with amendments thereof shall be read and interpreted together. However, in case of a contradiction between the Technical Specification and any other volume, the provisions of this volume will prevail.
- 2.4 The Battery Charger shall conform in all respects to high standards of engineering, design, workmanship and latest revisions of relevant standards at the time of offer and purchaser shall have the power to reject any work or materials, which in his judgment is not in full accordance therewith.

**3. STANDARDS:**

The equipment covered by this specification shall unless otherwise stated, be designed, constructed and tested in accordance with the applicable sections of the latest Indian Standard specification and Indian Electricity Rules.

	Standard Ref. No.	Title.

1.	IEC-60146	Specification for rectifier equipment in general
2.	IEC-60269	Specification for HRC fuses.
3.	IS-1248	Specification for Indicating Instruments.
4.	IEC-60529	Degree of protection
5.	IS-6619	Safety code for semi-conductor rectifier equipment.
6.	IS-2026	Transformers
7.	IEC-60947	A.C contactor for voltages not exceeding 1000V
8.	IEC-61810	Elementary Relays for voltages not exceeding 1000V
9.	IS-5	Colour for Ready Mix paint

#### 4. CONSTRUCTION:

- 4.1** It will be indoor, freestanding, floor mounting and naturally air cooled type, designed for continuous operation in the ambient temperature of 50°C. Good cross ventilation shall be made through side louvers to avoid any undue temperature rise in the panel.
- 4.2** Each charging equipment offered shall be housed in a sheet steel cubicle reinforced by angle iron frame and shall be mechanically strong. The cubicle shall be dust and vermin proof.
- 4.3** The rear and front door cover of the cubicle shall be hinged and shall have locking arrangement. Thickness of sheet steel shall be **3 mm** for load bearing members and **2 mm** for other sides.
- 4.4** Gland plate of **3 mm** thickness for incoming / outgoing cables shall be provided. Body earthing with two separate earthing terminals shall also be provided. Doors shall also be earthed with minimum **4sqmm** insulated copper wire.
- 4.5** All the door mounted equipment as well as equipment mounted inside the cabinet shall be provided with individual riveted /life lasting adhered labels with equipment description engraved.
- 4.6** Electrical indicating instruments shall be flush mounted on the panel with only flange projecting. The dial shall be white with black numbers and lettering.
- 4.7** The control electronics shall be built on plug in type glass epoxy printed circuit boards of modular design. The electronic control circuitry should have built in feature of soft start so that whenever the charger is switched on, the output voltage should increase gradually.
- 4.8** Battery Charger shall be provided with earth bus bar of tinned copper flat, having minimum cross section 20 x 3 Sq. mm flat securely fixed along with base and provision on both the sides of earth bus for connecting purchaser's earthing grid.
- 4.9** Each cubicle will undergo a thorough process of de-rusting, cleaning, application of red oxide primer paint followed by the two coats of light grey synthetic enamel paint shade 631 of IS: 5. Paint thickness shall be **minimum 80 microns**.
- 4.10** Power wiring for the chargers shall be done with 1.1KV grade, heavy duty, single core, stranded copper conductor PVC insulated cables or suitable sized PVC sleeved copper bus bars. Control wiring for the charger shall be done with 1.1 KV grade PVC insulated copper wires of cross section 2.5 sq. mm for all

control connection. Wire of 2.5 sq. mm cross section shall be used for control bus. All control wiring shall be ferruled.

**4.11** All equipment's and wiring used in the panel shall be tropicalised dust proof and vermin-proof.

## **5. DESIGN DETAILS AND DUTY REQUIREMENTS:**

**5.1** The charger shall be suitable for charging the battery and supplying the load simultaneously. The entire charger scheme shall be divided in two sections, "**float charger section**" and "**float-cum-boost charger section**". The float-cum-boost charger shall be suitably operated either in float mode or in boost-cum-standby float charger mode.

**5.2** The float and float –cum-boost sections of the charger shall be compatible to operate in auto (fully automatic) as well as manual mode with a provision of selection through Auto/Manual switch and all related components & scheme.

**5.3** Under normal operating condition, with the input AC supply present, the float charger section shall supply the DC load and also float the battery by trickle charging and the "float cum boost charger section" shall be kept off.

**5.4** In the event of main AC supply failure, the battery shall supply DC power to the Sub-station DC Load. The battery thus discharged shall be charged after resumption of A.C supply by the FCBC charger at the specified current needed for the battery depending on the extent of discharge. During this operation, 'the float charger section' shall continue to supply the load current only while float cum boost charger shall recharge the battery and the load supply shall be disconnected from the battery through a contact of a contactor. If the 'float charger' fails during this period, the battery shall maintain load through tap cell diode, connected at **84th cell(not exceeding a voltage more than 231 volt )** instantaneously without any interruption of the DC load supply. If the incoming AC supply or the boost charger fails during boost charging, all the cells shall be connected to the load bus through the contact of the same contactor mentioned above. In boost mode the charger shall be capable of quick charging the battery up to **2.75 Volts** per cell and also capable of restoring fully discharged battery to a state of full charge in eight hours.

**5.5** If there is any trouble in " float charger section ",the float mode of float cum boost charger section ", through Float-Boost selector switch shall supply the D.C. load as well as trickle charge the battery and thus serve as a spare float charger.

**5.6** **The complete logic of operation for battery charger is tabulated below:**

CASE	FC	FCBC	CONTACTOR	BATTERY	LOAD	DROPPER DIODE
1	FLOAT	STANDBY	CLOSE	FC-FLOAT	FC-FLOAT	ACTIVE
2	FLOAT	BOOST	OPEN	FCBC-BOOST	FC-FLOAT	ACTIVE
3	OFF	FLOAT	CLOSE	FCBC-FLOAT	FCBC-FLOAT	ACTIVE
4	OFF	BOOST	OPEN	FCBC-BOOST	FROM TAP CELL OF BATTERY	NOT IN CIRCUIT
5	OFF	OFF	CLOSE	DISCHARGE	BATTERY	BYPASS

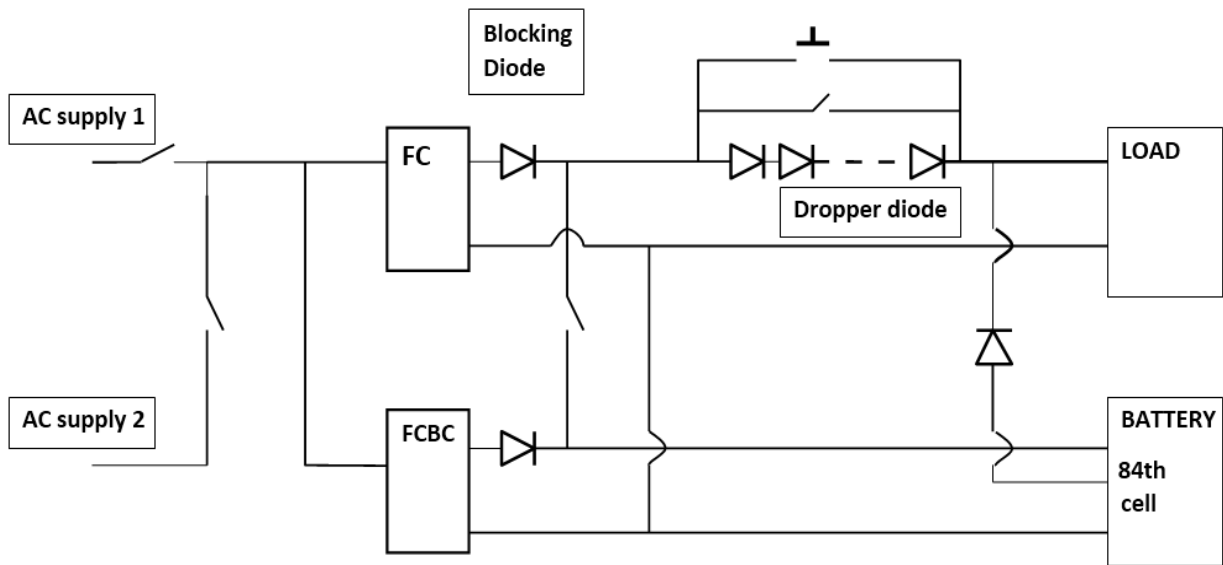

**Diagram - Schematic diagram of Battery Charger**

- 5.7** The 'FC' charger and 'FCBC' charger shall be complete with silicon controlled rectifier units, dry type air-cooled transformers, control electronics, smoothing filters etc. suitable for operation from 415V + 10%, 50 HZ + 5%, 3 phase A.C. supply. There shall be a provision for redundant A.C supply. In case of failure of one AC supply both FC and FCBC charger shall be able to avail power from redundant supply.
- 5.8** The charger output shall be stabilized to  $\pm 1\%$  of set value for -15% to + 10% input voltage variations and 0-100% load variation.

- 5.9** The battery charger shall have full-wave, Half-controlled thyristor controlled bridge rectifier circuit. The charger output voltage shall suit the battery offered. Ripple voltage shall be less than 3% RMS voltage.
- 5.10** Each charger panel shall incorporate all the necessary controls, Indications, interlocks, protective devices and timing features to ensure any operation.
- 5.11** Provision shall be made with necessary contact / relays for annunciation in the event of alternating current power failures to the charger and automatic shutdown of the charger by over-voltage / current devices. Annunciation shall however be prevented when the charger is manually shutdown or when A.C. power supply is momentarily interrupted for adjustable period of 1 to 5 seconds.
- 5.12** Each charger shall be protected against any damage from over voltage/ load currents and shall be so designed that it can continuously deliver at least rated current output without operation of the protective over-load device for abnormal conditions of low battery voltage down to 175V (80% of the rated voltage). But the chargers shall be disconnected from A.C. input supply through an over-voltage relay, if the input voltage exceeds 10% of the rated voltage of the equipment.
- 5.13** Necessary selector switches for 'Trickle Charging' and 'Quick charging' shall be provided. There shall be 'make before break' type blocking Diodes and other equipment to be shown in the drawing or otherwise found necessary for charging the battery without increasing the voltage beyond safe value across the load shall also be supplied by the Bidder.
- 5.14** The Float voltage shall have the provision for user selectable output voltage setting from 200 Volt to 253 volt DC while the Boost voltage shall have the provision of output voltage variation from 200 volt to 302 volt DC both in AUTO and MANUAL Mode. In case of AUTO mode, once the voltage adjustment is set by the user, there shall be no fluctuation of output voltage from the set value thereof. A dedicated potentiometer /Voltage Adjustment port shall be provided by the manufacturer for use of purchaser and the same shall be clearly indicated in the drawings pertaining to the battery charger.
- 5.15** The rectifier units of the chargers shall be capable of supplying an impulse load of 6/7 times its rated capacity. The trickle charger in conjunction with automatic voltage regulators shall have drooping characteristics, So as to transfer the load beyond its capacity to the battery.
- 5.16** The incoming and outgoing circuits shall be provided with MCCBs with static releases for overload, short circuit and earth fault protections. The incoming power supply to the chargers will be from two sources with a facility of changeover switch. The change over facility shall be provided in the charger itself.
- 5.17** Adequately rated HRC fuse protection over and above a rated load break isolator switch shall be provided for isolating the charger output form battery source.
- 5.18** Input volt meter and ammeter shall be of moving iron type and shall be 96 x 96 mm. Square. These meters shall be of accuracy class not less than 1.0 and shall be of flush mounting type with required PTs and CTs and selector switches. Output voltmeter and ammeter shall be moving iron type and shall be 96 x 96 mm square. The meter shall be of accuracy class not less



than 1.0 and shall be flush mounting type. The ammeter shall be center zero type for measurement of charging and discharging current from the battery.

## 6. ANNUNCIATION AND INDICATION CIRCUITS:

**Following Cluster LED lamps shall be provided in the charger panels:**

- 'Input supply On' condition
- 'Output Supply on' condition
- Float Mode on / off
- Boost Mode on / off.

**Annunciation with audiovisual alarms shall be provided for the following.**

- Input mains failure.
- Input phase failure.
- Input fuse failure.
- Rectifier fuse failure.
- Filter fuse failure
- DC over voltage
- DC under voltage
- Output fuse failure
- Charger over-load
- Earth leakage
- Alarm supply fuse failure
- Charger trip
- Output MCCB tripped
- AC under voltage
- Battery low condition
- Dropper Diode Ckt Open /Bypass Contactor Failure

**ACCEPT, TEST AND RESET** push buttons shall be provided. 20% spare annunciation windows shall be provided.

## 7. DROPPER DIODE CIRCUIT:

The Dropper Diode Circuit will include Dropper Diodes & Contactors associated with Voltage Sensing Relay PCBs. The Charger Output Voltage will be sensed by the Voltage Sensing Circuit Board which is set at required voltage level. Whenever the System Output Voltage is higher than the set Voltage level, then that particular sensing Circuit will turn ON, activating the relay of the Relay Board which in turn opens the Contactor & the Dropper Diode will drop the excess voltage so that the Output Voltage is maintained as required. If the Output Voltage is less than the Set Value, the Contactor will be made ON automatically & the Dropper Diodes will get bypassed. **There should be a provision to have a switch/MCB with minimum 25 Amp**

continuous make and break capacity (The switch terminals must be wired across the dropper diode and bypass contactor) so that in the event of dropper diode open circuit or bypass contactor failure, the switch can be made ON for catering system D.C load without significant interruption. An alarm with Hooter must be provided to convey the information that “DIODE CKT OPEN OR BYPASS CONTACTOR FAILURE” so that manual intervention can be swiftly made to restore the loss of D.C supply to the system.

The above arrangement shall preferably be customized with in the same battery charger cabinet instead of a separate cabinet so as to avoid space consumption.

**8. SCADA COMPATIBILITY:**

The Battery Charger shall be fully SCADA compatible. It shall have sufficient nos of potential free contacts & transducers (4-20mA output (min. 2 nos. output port)) for digital and analogue signals respectively. It shall also be possible to control various functionality of Battery Charger from SCADA system through hard wire connection. Typical input status requirement is tabulated here under. However exact number and description shall be as per detailed engineering.

PARAMETERS	DIGITAL INPUTS	ANALOGUE INPUTS (4-20mA)
AC mains fail	√	
DC Over Voltage	√	
DC Under Voltage	√	
Float Charger fail	√	
Earth Leakage	√	
Dropper Ckt. Open/Bypass Contactor Failure	√	
Float Charger On	√	
Float Charger Off	√	
Float Charger on Auto mode	√	
Float Charger on Manual mode	√	
FCBC Charger On	√	
FCBC Charger Off	√	
FCBC charger on Float Mode	√	
FCBC charger on Boost Mode	√	
Battery Voltage		√
Boost Voltage		√
Float Voltage		√
Load Voltage		√
Battery Current		√
Boost Current		√
Float Current		√
Load Current		√
Battery Room Temperature		√

**Note: Any other item(s), not stipulated in this specification, but required for installation, operation and maintenance of the battery charger is / are included in the scope of supply without any extra charge on OPTCL.**

**9. TESTS:**

**A. TYPE TESTS:-**

The following type test reports from NABL accredited laboratory as per *applicable* standard for Battery chargers shall *be submitted with technical bid*. Rectifier transformers shall conform to all type tests specified in IEC - 60146 and short circuit test as per IS: 2026. The type test reports shall ***not be older than seven years from the expiry of the validity of the offer. Tests shall be carried out as per procedures specified in Appendix-II.***

1. Voltage regulation test
2. Load limiter characteristics test
3. Measurement of Efficiency and power Factor
4. High voltage test
5. Temperature rise test
6. Short circuit test at no load and full load at rated voltage for sustained short circuit.
7. Degree of protection test – **IP 42**
8. Measurement of ripple by Oscilloscope
9. Temperature compensation feature demonstration
10. Type test reports of Rectifier Transformers - all tests as specified in IEC -60146 and short circuit test as per IS : 2026

**Important Note:**

**In case of non-submission of some the type test reports, the bidder shall confirm the submission of same before commencement of supply, without affecting delivery schedule, from NABL accredited laboratory, free of cost. In absence of this confirmation, the offer will be evaluated as non-submission of type test report.**

**B. ACCEPTANCE TESTS:**

Followings shall constitute the acceptance tests which shall be tested by the purchaser's representative at the works of the manufacturer at the cost of the supplier (both for FC & FCBC) for each charger. No sampling is allowed.

- (a) Visual inspection and dimension check
- (b) Measurement of voltage regulation / AVR Regulation
- (c) Efficiency and power factor measurement
- (d) Temperature rise test so as to determine the temperature rise of SCR, Transformer primary, secondary and core, diode, capacitor, choke and cabinet etc.
- (e) Measurement of insulation resistance.
  - (1) AC input to earth

- (2) AC input to DC output
- (3) DC output to earth
- (f) Test for rectifier transformer (all relevant tests as per corresponding ISS)
- (g) High voltage tests.
- (h) Measurement of ripple
- (i) Operational test for protection, Alarm & indication and Auto/Manual operation etc.
- (j) Tests for indicating instruments.
- (k) Determination of system set points.
- (l) Soft start test

**N.B.: The supplier shall provide arrangements for monitoring the temperature across the elements, as stipulated above, continuously during the temperature rise test without disconnection of any of the temperature measuring devices across the hottest spot of each of the above elements.**

All other tests, as may be necessary to ensure that all equipment's are satisfactory shall also be carried out. In addition to the above tests, manufacturer's test certificates, vendor's test certificates for different equipment's, accessories, instruments etc. shall be submitted, whenever required by the purchaser.

#### **10. DRAWINGS / DOCUMENTS:**

The bidder shall submit the following drawings / documents along with his offer failing which the offer is liable for rejection.

- (a) OGA of the battery chargers.
- (b) General layout with overall dimensions.
- (c) Electrical schematic diagram showing connections and controls.
- (d) Leaflets and technical literature giving detailed information of the panels offered.

The manufacturer shall submit the following drawings / documents in 3 (three) copies within 15 (fifteen) days from the date of issue of the purchase order for purchaser's approval.

- (a) OGA of the battery chargers.
- (b) General layout with overall dimensions marked along with sectional views showing cable entry position etc.
- (c) Rating calculations for transformer, rectifiers, diode, capacitor, inductor and characteristic of DC curve etc.
- (d) Detailed schematic and connection and control wiring diagram for all the equipment.
- (e) Complete bill of materials.
- (f) Technical excerpts on operation.
- (g) The circuit diagram of charger including circuit diagrams of all cards to facilitate the maintenance of chargers
- (h) Charger Operation Logic

- (i) **Manufacturing Quality plan of Battery Charger.**
- (j) **Raw Material and critical components (SCR, Diode, Filter and contactors etc.) test certificates.**

## **11. SPECIAL TOOLS, PLANTS AND SPARES**

The tender shall quote for recommended special tools, plants and spares, considered necessary for installation and maintenance of batteries and charges for a minimum period of 5 (five years.)

The following mandatory spares are to be quoted by the bidder in the price bid:-

- (a) Voltage regulator cards- 1 No/Charger.
- (b) Protection card (if any)- 1 No/ Charger.
- (c) Thyristor (SCR)- 2 Nos. for F.C.+ 2 Nos. for B.C./ Charger.
- (d) Blocking Diode- 1 No. for F.C. + 1 No. for B.C./ Charger.
- (e) Filter Capacitor- 1 Set/Charger.
- (f) Auto-manual switch- 1 No. for F. C. + 1 No. for B.C./ Charger.
- (g) Indicating LED- 10 Nos./Charger
- (h) Indicating fuse (if any)- 10 Nos./Charger
- (i) Input A.C. contactor- 1 No. for F.C., + 1 No. for B.C./ Charger
- (j) Rectifier H.R.C. fuses- 4 Nos. for F.C. + 4 Nos. for B.C./Charger.
- (k) DC Voltage Transducer (4-20 mA): 1Nos.
- (l) DC Current Transducer (4-20mA): 1 Nos.

## **12. TRANSPORT:**

The equipment shall be dispatched securely packed in wooden crates suitable for handling during transit by rail / road, so as to avoid any loss or damage during transit. The crate should be marked with the legible details like Make, Sr.No. , Type of Charger and A/T (purchase order) no. etc.

Three sets of each of the detailed dimensional drawings, commissioning and operating instructions manual, literature, write up and test certificates of bought items shall be supplied with each of the battery charger.

**APPENDIX-I**

**GENERAL TECHNICAL REQUIREMENTS FOR BATTERY CHARGER SUITABLE FOR  
220 V 350AH VENTED LEAD ACID BATTERY**

1	Type	Float & Float cum boost charger, full wave, half controlled type/full control.	
2.	RATINGS	220V/35A/60A Float & Float cum Boost Charger (Suitable for Plante Battery)	
3.	AC INPUT (a) Voltage (b) Frequency (c) Phase	415VAC $\pm$ 10% 50Hz $\pm$ 5% 3-phase-4 wire	
4.	D.C.OUTPUT VOLTAGE SELECTION SETTINGS(IN BOTH AUTO AND MANUAL MODE) <b>Adjustable Range</b>	FC <b>(voltage variation adjustable from 200 volt to 253 volt)</b>	BC <b>(voltage variation adjustable from 200 volt to 302 volt)</b>
5.	OUTPUT CURRENT LIMIT	35A	60A
6.	POWER CONVERSION	AC to DC by means of three phase full wave, Half controlled bridge rectifier consisting of thyristors and diodes.	
7.	VOLTAGE REGULATION AT BRIDGE OUTPUT.	$\pm$ 1% of set value for $\pm$ 10% Input Voltage Variations, 0-100% Load variation.	
8.	RIPPLE VOLTAGE	Less than 3% RMS without battery connected.	
9.	EFFICIENCY	More than 75% at full load	
10.	PROTECTIONS		
	(a) Input side	AC input MCCB with input ON/OFF switch and fuses, contactor (for source-1&2 with interlocking)	
	(b) Output side	DC output MCCB with output ON/OFF switch and fuses contactor.	
	(c) Protection	Current limit protection, soft start feature, surge suppressor. Fast semiconductor fuses for rectifier bridge.	
	(d) control circuit	Fuses	
	(e) Capacitor circuit	Rectifier HRC fuses.	
	(f)	Over-voltage cut-back	
	(g)	Charger over load / short circuit	
	(h)	Blocking diode	
11.	CONTROLS AND SWITCHES	Followings controls and switches are provided in the system a) AC input source MCCBs with interlocking b) DC output MCCB c) Auto/Manual, float/boost mode selector switch. <b>d) Float and boost voltage variable potentiometers (for both auto and manual mode).</b>	

		e) Manual voltage adjustment Potentiometer f) Test push button g) Reset push button h) Battery current adjustment potentiometers i) Heater's power supply switch j) Socket power supply switch	
12.	FEATURES	The following features are provided in the systems: a) Soft start on DC side b) Class-F insulation for all magnetic material. c) Automatic voltage regulation. d) Automatic changeover from float to boost and vice versa based on current, drawn by battery. e) Filter circuit to eliminate ripple. f) Charger current limit g) Separate battery path current limit. h) Built-in auto phase reversal of operation.	
13.	Meters	(i) Input Voltmeter (ii) Input Ammeter (iii) Output Voltmeter (iv) Output Ammeter	(i) Common (ii) Input Ammeter (iii) Output Voltmeter (iv) Output Ammeter.
		Battery volt meter Battery ammeter Earth leakage ammeter	
14.	Indications	(i) R,Y,B Phase 'ON' lamps (ii) Output 'ON' lamp	(i) R.Y.B. phase 'ON' lamps (ii) Output 'ON' lamp. (iii) Charger 'ON' float LED (iv) Charger 'ON' boost LED.
15.	Annunciation with audiovisual alarms.	(i) AC input mains failure (ii) Input phase failure (iii) AC under voltage (iv) Input phase failure (i) Rectifier fuse failure (ii) Output fuse failure (iii) Filter fuse failure (iv) DC under voltage (v) DC over voltage (vi) Charger trip (vii) Capacitor fuse fail (viii) Output MCCB tripped (ix) Charger over load (x) Earth leakage (xi) DC earth fault (xii) Alarm supply fuse failure	v) Rectifier fuse failure vi) Output fuse failure vii) Filter fuse failure viii) DC under voltage ix) DC over Voltage x) Charger trip xi) Capacitor fuse fail xii) Output MCCB tripped.

		(xiii) Battery low condition.	
Note : All the alarms shall be provided through electronic display cards. Audio alarm through buzzer, visual indication through 10 mm LEDS & alarm ackn. / reset and LED provision is through push buttons.			
16.	Operating ambient temperature surrounding the panel	0 <sup>0</sup> to 50 <sup>0</sup> C	
17.	Surrounding the panel Relative humidity.	0-95% non-condensing	
18.	PANEL (a) Protective grade (b) Cooling (c) Paint	(a) IP – 42 (b) Natural air-cooled (c) Smoke Grey of ISS-692 shade	
19.	MAGNETICS : (a) Average winding temperature rise over ambient temperature	45 <sup>0</sup> Cover an ambient temperature of 50 <sup>0</sup> C.	
	(b) Insulation class	'F'	
	(c) Insulation breakdown voltage.	3 KV for 1 min withstand.	
20.	CABLES	1100 V grade PVC insulated copper. Ferrules shall be provided for identification of connection.	
21	Dropper Diodes to be connected in series	20Nos.	
22	SCADA Compatibility	As per Clause No.8	

**N.B. :** - Besides the above general technical requirements, all other stipulations, as enumerated in this technical specification shall be followed. Any deviation should be clearly brought out with clear explanation.

Any extra feature/ equipment / instrument as necessary for operation and performance of the battery charger for the 220V battery set as per this specification shall be provided without any extra cost to OPTCL.

### **ANNEXURE-A**

#### **GUARANTEED TECHNICAL PARTICULARS FOR BATTERY CHARGER (220 V D.C. SYSTEM) SUITABLE FOR 220V, 350AH**



**VENTED LEAD ACID STORAGE BATTERY (Plante type)****(To be filled in by the Bidder)**

<b>SL.NO.</b>	<b>DETAILS</b>	<b>VALUES &amp; OTHERS</b>
1.	Manufacturer's Name	
2.	<b>Rated output of the charger</b>	
3.1	Voltage (volts)	
2.2	Current (amps)	
2.3	Power factor	
3.	Short time rating	
4.	Type of cooling	
5.	Hottest stack temperature (°C)	
6.	<b>Charger dimensions</b>	
6.1	Height (mm)	
6.2	Depth (mm)	
6.3	Width (mm)	
6.4	Sheet thickness (mm)	
7.	Charger weight	
8.	<b>Charger rated output current</b>	
8.1	Float charging mode	
8.2	Boost charging mode	
9.	Load limiter current setting range (Trickle mode)	
10	<b>RECTIFIER TRANSFORMER</b> Float      Boost Charger      Charger	
10.1	Make	
10.2	Type	
10.3	Rated KVA	
10.4	Over current impedance (ohms)	
10.5	Input line winding connection in vector representation	
10.6	Rated primary voltage (volts)	
10.7	Rated secondary voltage (volts)	

10.8	Rated frequency (Hertz.)	
10.9	Rated output (amps)	
10.10	Turn ratio	
10.11	Insulation level	
10.12	Impulse withstand test voltage (KVP)	
10.13	One minute power frequency over voltage.	
	(a) Primary winding (KV-rms).	
	(b) Secondary winding (KV-rms)	
10.14	Material of primary winding conductor	
10.15	Material of secondary winding conductor	
10.16	Size, Cross-sectional area and current density of primary winding conductor.	
10.17	Size, cross-sectional area and current density of secondary winding conductor	
10.18	No. of turns of primary / phase	
10.19	No. of turns of secondary / phase	
10.20	Name of the insulating materials used and class	
10.21	Core	
10.21.1	Name of the core material	
10.21.2	Grade of the core	
10.21.3	Thickness of core material (mm)	
10.22	Maximum temperature rise over an ambient temperature of 50°C	
	(a) Primary Winding (°C)	
	(b) Secondary Winding (°C)	
	(c) Core (°C)	
10.3	standards applicable	
<b>11.0</b>	<b>RECTIFIER ASSEMBLY :</b>	
11.1	11.1Make	
11.2	Type of semi-conductor material	
11.3	Rated direct current per cell (A)	
11.4	Rated direct voltage (V)	
11.5	Rated input voltage (V)	

11.6	Type of connections of rectifier elements.	
11.7	Forward power loss and reverse power loss (watts).	
11.8	Forward voltage drop and reverse voltage drop (volts)	
11.9	Conversion efficiency (%)	
11.10	Rated DC output voltage (V)	
11.11	Rated AC input voltage (V)	
11.12	Rated output current (A)	
11.13	Ripple factor	
11.14	Voltage factor	
11.15	Current factor	
11.16	Maximum temperature rise over an ambient temperature of 50°C (°C)	
11.17	Maximum permissible ambient temperature for guaranteed rating (°C)	
11.18	Maximum and minimum permissible humidity rating (%)	
11.19	Life expectancy (years)	
11.20	Standard(s) applicable	
11.21	Characteristic curve of DC output plotted against output current (Whether submitted?) Yes / No.	
12.	<b>AUTOMATIC VOLTAGE REGULATOR</b>	
12.1	manufacturer's name	
12.2	Manufacturer's type	
12.3	Percentage stabilization of the rectifier with the help of AVR when	
	(a) Input voltage changes with $\pm$ of its nominal value.	
	(b) DC output of the rectifier varies from no-load to full load.	
12.4	Rated output voltage	
12.5	Allowable AC frequency fluctuations	
12.6	Voltage setting range	
12.7	Response time of automatic voltage regulator	
13.0	<b>User Selectable voltage regular (in both FC and FCBC))</b>	
13.1	Voltage Regulator(for Manual Mode)(Provided or Not)	

13.1.1	Type	
13.1.2	Voltage setting range	
13.2	Voltage Regulator(for Auto Mode)(Provided or Not)	
13.2.1	Type	
13.2.2	Voltage setting range	
14.0	Boost charging current setting range	
15.0	Boost charging limit setting range	
16.0	<b>DIODES</b>	
16.1	Manufacturer's name	
16.2	Type of circuit	
16.3	Method of construction	
16.4	Continuous current rating (Amps.)	
16.5	Short time current rating (Amps)	
16.6	Type of cooling	
16.7	Forward power loss and reverse power less (W)	
16.8	Life expectancy	
16.9	Forward voltage drop on rated current	
16.10	Resistance offered for reverse current flow	
16.11	Maximum temperature rise over an ambient temperature of 50° C.	
17.0	<b>CONTACTORS / MOULDED CASE CIRCUIT BREAKERS</b>	
17.1	Type	
17.2	Make	
17.3	Rated voltage (V)	
17.4	Rated continuous currents (A)	
17.5	Contact material	
17.6	Operating coil	
17.6.1	Voltage (V)	
17.6.2	Voltage range and power for closing and holding	
17.6.3	Voltage range and power for drop off.	
17.7	Thermal trip rating	
17.8	Thermal trip time	

17.9	Details of CT if any	
17.10	Auxiliary contacts	
17.10.1	Number	
17.10.2	Current rating	
17.11	Characteristics of back-up HRC fuse	
18.0	<b>RELAYS :</b>	
18.1	18.1 Make and type of protective and alarm relays	
	(a) Thermal overload relay	
	(b) Input under voltage relay	
	(c) Single phasing alarm relay	
	(d) Phase reversal relay	
	(e) D.C. output over-voltage relay	
	(f) D.C. output under voltage relay	
	(g) Charger failure relay	
	(h) Battery earth fault relay	
	(i) A.C. input failure relay (for connecting the D.C. load)	
	(j) Fuse failure relay	
	(k) Alarm accept relay	
18.2	Rated voltage of each of the above	
	(a) AC/DC	
	(b) Permissible variation	
	(c) Frequency	
18.3	VA burden of each of the above	
18.4	Operating time of each of the above	
18.5	Time vs current curves of each of the above (to be enclosed along with the offer)	
18.6	Reset time	
18.7	Accuracy	
18.8	Setting range	
18.9	Reset factor	
18.10	Number of contacts	
	(a) Normally open	

	(b) Normally closed	
18.11	Rating of contacts	
	(a) Rated Voltage (V)	
	(b) Rated making and breaking	
	(c) Continuous rating	
18.12	No. of operations	
18.13	Operation indicator	
19.0	<b>INDICATING LAMPS</b>	
19.1	Manufacturer's name	
19.2	Type and designation	
19.3	Permissible voltage variation	
19.4	Rated power consumption (watts).	
19.5	Series resistance, if any	
20.0	<b>SWITCHES:</b>	
20.1	Manufacturer's name	
20.2	Ratings	
	(a) Continuous current	
	(b) Short circuit – making capacity	
	(c) Breaking capacity	
	(d) Voltage	
20.3	Operating mechanism details	
20.4	Type of visual indication	
	(a) OFF and ON position	
	(b) Fuse blow out	
21.0	<b>FUSES</b>	
	(a) Make	
	(b) Type	
	(c) Rating (Amps)	
	(d) Interrupting rating (KA)	
22.0	<b>INSTRUMENTS</b>	
22.1	Manufacturer's Name	
	(a) Ammeter	
	(b) Voltmeter	

22.2	Type	
	(a) Ammeter	
	(b) Voltmeter	
22.3	Standard	
	(a) Ammeter	
	(b) Voltmeter	
22.4	Scale range.	
22.4.1	Ammeter	
	(a) Float charger	
	(b) Boost charger	
	(c) Battery float	
	(d) Battery boost	
22.4.2	Volt meter	
	(a) Input supply	
	(b) Charger output	
	(c) Load	
22.5	Size of dial	
	(a) Volt meter	
	(b) Ammeter	
22.6	Accuracy Class	
	(a) Volt meter	
	(b) Ammeter	
22.7	Temperature at which calibrated	
22.8	Limit of errors	
22.10	Out line dimensions	
22.10	Type of mounting	
22.11	Selector switch for volt meter (AC & DC)	
	(a) Make	
	(b) Rating	
23.0	<b>CAPACITOR</b>	
23.1	Manufacturer's name	
23.2	Type	
23.3	Capacitance (Farad)	

23.4	Maximum temperature rise over an ambient temperature of 50°C.	
24.0	Reference float voltage at ambient temperature of 27°C	
25.0	Whether protection is given for float voltage to Avoid low battery voltage due to sensor or circuit Malfunction. (Yes/ No)	
26.0	Whether the Battery Charger is SCADA Compliant as per Clause No.8(Yes/ No)	
27.0	Whether Temperature Sensor provided in the charger panel for SCADA. (Yes/ No)	
28.0	Whether 20Nos. Dropper Diodes along with its accessories/Associated circuits as per Clause No. 7 provided or not (Yes/No)	

**APPENDIX-II**

**Type test procedure for Battery Charger**

Sr. No	Test description
1	<p><b><u>Voltage regulation test:</u></b></p> <p><b>A) Float charger</b>  <b>B) Float mode of boost charger:</b>  <b>Test condition: -</b></p> <ul style="list-style-type: none"> <li>▪ The adjustment of output voltage at no load is verified by front panel Potentiometer.</li> <li>▪ Output voltage of charger is set at maximum voltage setting and input voltage is varied from -15% &amp; +10% of nominal volts; Variation in output voltage is verified.</li> <li>▪ The unit is loaded up to 100% rated load and output voltage is observed. Under this condition, the input voltage is varied as specified above and variation in output voltage is verified. Regulation should be limited to or less than <math>\pm 1\%</math> of rated output voltage of the charger.</li> </ul>
2	<p><b><u>Load limiter characteristics test: -</u></b></p> <p><b>A) Float charger</b>  <b>B) Float mode of boost charger:</b>  <b>Test Condition: -</b></p> <ul style="list-style-type: none"> <li>▪ The current limit potentiometer is adjusted such that current limit starts beyond 100% load i.e. current beyond rated current. Now Load resistance is reduced and drooping characteristic of output voltage is verified.</li> </ul>



<p>3</p>	<p><b><u>Efficiency test:</u></b></p> <p><b>To be carried out on Float Charger &amp; Boost Charger separately at max. Power rating.</b></p> <p><b>Test condition: -</b></p> <ul style="list-style-type: none"> <li>▪ Float charger: - Efficiency test is carried out at nominal AC input voltage , DC output voltage adjusted to maximum voltage setting, by loading only the Float charger at 20%, 50%, &amp; 100% load of rated current at Feeder Terminals &amp; keeping the Boost charger</li> <li>▪ “OFF”. AC input power is measured by Digital/Analog Power Meter and DC output is measured by calibrated Voltmeter and Ammeter other than the provided in the Float charger.</li> <li>▪ Boost Charger: - Efficiency test is carried out as per above procedure for Boost Charger keeping float charger “OFF” &amp; adjusting maximum voltage setting at Battery Terminals with Boost Charger constant current setting at 20% 50% &amp; 100% load of rated current with the help of suitable resistors at Battery Terminals.</li> <li>▪ Efficiency should be better than 75% at 20% load &amp; better than 80% at 50 % &amp; 100% load as per GTP.</li> </ul>
<p>4</p>	<p><b><u>High voltage test:</u></b></p> <p><b>Test condition: -</b></p> <ul style="list-style-type: none"> <li>▪ The power frequency voltage of 2 KV shall be applied between AC circuit &amp; Earth, DC circuit &amp; Earth and AC circuit &amp; DC circuit for 1 Minute. During High Voltage Test, all low voltage circuits (Electronics circuit, Lamps etc.) are isolated and gate – cathode, anode – cathode terminals are shorted. Charger should withstand it and there shall not be any mal function or deformation and it should work satisfactory after the test.</li> </ul>
<p>5</p>	<p><b><u>Temperature rise test: - Test Condition: -</u></b></p> <ul style="list-style-type: none"> <li>▪ Rated mains supply is to be applied to charger. Float charger DC Output voltage to be set to maximum voltage setting &amp; load current is to be adjusted to 100% rated load of float charger at feeder terminals &amp; simultaneously Boost charger DC Output current is to be set to 100% rated load of boost charger by variation of set boost current potentiometer on front panel. Battery terminal voltage is to be adjusted to maximum voltage setting of Boost Charger by varying the resistive load connected to “Battery Terminals”. Temperature readings of ambient temperature, Float &amp; Boost Rectifier Stack heat sink, windings &amp; cores of Float &amp; Boost Rectifier Transformer &amp; filter choke, &amp; to be noted for every hour, till temperature rise is stable. After completion of this test Normal functioning of the battery Charger to be verified by carrying out the following tests:</li> </ul> <p style="padding-left: 40px;">1) High voltage.</p>

	<p>2) Voltage regulation test. 3) Short circuit Test.</p>
<p>6</p>	<p><b><u>Short circuit test at no load and full load at rated voltage for sustained short circuit at load Terminals:</u></b></p> <p><b>A) Float charger (Auto mode).</b> <b>B) Float mode of Boost charger (Auto Float)Test condition: -</b></p> <ul style="list-style-type: none"> <li>▪ This test is carried out on LOAD TERMINALS with Float charger &amp; Float mode of Boost Charger. The output DC voltage at load terminal is adjusted maximum voltage setting with rated AC input volts. The load terminals are shorted with following test conditions. <ul style="list-style-type: none"> <li>1) No load at load terminals</li> <li>2) Full load of rated current at Load Terminals.</li> </ul> </li> <li>▪ In no load condition, the load terminals are shorted first and then charger is switched ON. Moreover, in full load condition, increase the load from rated current 100% to till short circuit at LOAD TERMINALS. The Battery Charger should sustain this short circuit with mains variation from -15% &amp; +10% of nominal input volts and the Battery charger should function normal after removal of short circuit at load terminals.</li> </ul>
<p>7.</p>	<p><b><u>Temperature Compensation Feature Demonstration test:</u></b></p> <p><b><u>Auto Float Charger Test condition: -</u></b></p> <ul style="list-style-type: none"> <li>▪ To observe that DC output of Battery Charger changes proportional to 4-20 mA input signal available from temperature transducer. The required change in output voltage is 3mV per 1°C per cell of 2volts of L. A. Battery. The temperature transducer produces 1mA signal per 2.5° C change in ambient temperature.</li> <li>▪ Therefore for 55 Cells (110V Battery Set), it will be 7.5mV x 55 Cells = 0.4125V per mA. The charger output voltage should decrease by 0.4125V for increase of 1 mA and vice-verse. The reference temperature is 27° C at which 11mA signal will be available from transducer.</li> <li>▪ The charger output should be set to 121V (i.e. rated output) at 11mA signal. The input signal should be changed from 4 mA to 20mA &amp; DC output should be observed. The DC output should vary @ 0.4125Volts per mA.</li> <li>▪ Similarly, for 110 Cells (220V Battery Set), it will be 7.5mV x 110 Cells = 0.8250V per mA. The charger output voltage should decrease by 0.8250V for increase of 1 mA and vice-verse. The charger output should be set to 242V (i.e. rated output) at 11mA signal. The input signal should be changed from 4 mA to 20mA &amp; DC output should be observed. The DC output should vary @ 0.8250Volts per mA.</li> </ul>

8	<p><b><u>Degree of protection test: -</u></b></p> <ul style="list-style-type: none"> <li>▪ Degree of protection shall be IP 42.</li> </ul>
9	<p><b><u>Measurement of ripple by Oscilloscope: -</u></b></p> <ul style="list-style-type: none"> <li>▪ AC supply with variation (<math>\pm 15\%</math>) &amp; Frequency variation (<math>\pm 3\%</math>) shall be supplied to the charger and ripple in the output voltage at 0, 50 &amp; 100 % load shall be measured with the oscilloscope. It shall be within <math>\pm 3\%</math>.</li> </ul>
10	<p><b><u>Type tests of Rectifier Transformers</u></b></p> <ul style="list-style-type: none"> <li>▪ All tests as specified in IEC 60146 and short circuit test as per IS: 2026.</li> </ul>

**ANNEXURE – C**

**(For Testing of Battery Charger)**

**(To be filled in by the bidder)**

**CALIBRATION STATUS OF TESTING EQUIPMENTS AND INSTRUMENTS/ METERS**

Name of the Test	Meters & Equipment required for the corresponding test with range, accuracy, make & Sl. No.	Date of Calibration	Due date of Calibration	Name of the Calibrating Agency	Whether Calibrating Agency is Govt. approved	Whether documents relating to Govt. approval of the calibrating Agency furnished	Whether the meters/ equipment fulfill the accuracy class as per calibration report.	Whether the calibrating agency has put any limitation towards the use of the particular meter/ equipment. If yes state the limitations	Whether the calibrating agency has put any limitation towards the use of the particular meter/equipment/ meter. State the colour of the affixed sticker	In spite of imposed limitations. Whether the particular meter / equipment can still be used? Justify its use for corresponding test(s)	Remarks
1	2	3	4	5	6	7	8	9	10	11	12

**Signature of the Bidder with seal & date**

**ANNEXURE -D**

**(To be filled in by the bidder)**

**CHECK LIST TOWARDS TYPE TEST REPORTS FOR BATTERY CHARGER**

Name of the Type Test	Date of Test	Name of the Laboratory where the Test has been conducted	Whether the Laboratory is Government approved	Whether the Test report is valid as per Spn.	Whether the Test report in complete shape along with drawings etc. furnished or not?	Whether the type tested battery charger fulfills the technical requirements as per TS	If the type tested battery charger does not fulfill the technical requirements as per this specification, whether the bidder agrees to conduct the particular type test again at their own cost without any financial liability to OPTCL in the presence of OPTCL's representative within the specified delivery period	Remarks
1	2	3	4	5	6	7	8	9

**Signature of the Bidder with seal**

## **PART – II**

### **PRICE BID**

#### **1. PRICE:**

- (i)** Bidders are required to quote their price(s) for goods offered indicating they are 'FIRM'
- (ii)** The prices quoted shall be FOR Destination only at the consignee's site/store inclusive of packing, forwarding, Freight & Insurance. In addition, the break-up of FOR Destination price shall be given as per schedule of Prices in Annexure-V of Section – III. The Bidder has to certify in the price bid that benefit of Input Tax Credit, Lower Implication of Tax if any, has been fully passed on to the Purchaser, while quoting the tender prices.

#### **2. INSURANCE :**

Insurance of materials/equipment, covered by the Specification should normally be done by the Suppliers with their own Insurance Company unless otherwise stated. The responsibility of delivery of the materials/equipment at destination stores/site in good condition rests with the Supplier. Any claim with the Insurance Company or Transport agency arising due to loss or damage in transit has to be settled by the Supplier. The Supplier shall undertake free replacement of equipment/materials damaged or lost which will be reported by the Consignee within 30 days of receipt of the equipments/materials at Destination without awaiting for the settlement of their claims with the carriers and underwriters.

#### **3. CERTIFICATE FOR EXEMPTION FROM GOODS AND SERVICES TAX:**

Offers with exemption from Goods and Services Tax shall be accompanied with authenticated proof of such exemption. Authenticated proof for this clause shall mean Photostat copy of exemption certificates, attested by Gazetted Officers of State or Central Government.

#### **4. PROPER FILLING UP OF THE PRICE SCHEDULE:**

- (i)** ~~In case where Freight & Insurance charges are not furnished, 5% of the Ex-works price shall be considered as the freight & Insurance charges.~~
- (ii)** The Bidder should fill up the price schedule (Annexure-V of Section-III) properly and in full. The tender may be rejected if the schedule of **price is**

submitted in incomplete form as per clause-34 (ix) of Section-II of the Specification.

**5. NATURE OF PRICE INDICATED IN SPECIFICATION SHALL BE FINAL.**

The nature of price indicated in the Clause-13, Section – I of PART –I of the Specification shall be final and binding.