



ODISHA POWER TRANSMISSION CORPORATION LTD

OFFICE OF THE ENGINEER - IN- CHARGE

BHARATNET PHASE-II PROJECT

**JANPATH, BHUBANESWAR – 751022.
Email id :eic.bharatnet_ph2@optcl.co.in**

TENDER SPECIFICATION

NO. EIC. BharatNet –e-Tender-2 /2026-27

**FOR SUPPLY TYPE-I 24F/48F/96F ADSS ACCESSORIES
(E tendering mode only)**

Sl. No.	ITEM DESCRIPTION	UNIT	Total Qty.
1	T.Buckle with E-link for cable dia 14mm+/-0.5mm.(TYPE-I)	Nos	17920
2	C.Thimble for cable dia 14mm+/-0.5mm. .(TYPE-I)	Nos	15962
3	P.Helix for cable dia 14mm+/-0.5mm. .(TYPE-I)	Nos	11605
4	T.Helix for cable dia 14mm+/-0.5mm. .(TYPE-I)	Nos	11605
5	UPC with 3 sets of N/B/W and SS304 Split pin duly covered with HSS abrasion protection.	Nos	4851

Request for online tender documents – From Dt- 01.07.2026 (10.00 AM) to Dt- 21.07.2026 (12.30 PM)

Last date of submission of online tender - Dt- 21.07.2026 (17.30 PM)
Date of opening of Tender - Dt- 22.07.2026 (03.00 PM)
Pre-bid conference - Dt- 13.07.2026 (11 AM)(online)

Email id: eic.bharatnet_ph2@optcl.co.in

Mobile:9438907447



ODISHA POWER TRANSMISSION CORPORATION LTD.

REGD. OFFICE: JANPATH, BHUBANESWAR – 751 022,

ODISHA

NO. EIC. BharatNet –e-Tender-2 /2026-27

For and on behalf of ODISHA POWER TRANSMISSION CORPORATION LTD, Engineer – in-Charge [BharatNet] invites Tenders from reputed manufacturers in two part bidding system for supply of TYPE-I 24F/48F/96F ADSS accessories. The interested bidders would be required to enrol themselves on the tender portal www.tenderwizard.com/OPTCL. Complete set of bidding documents are available at www.tenderwizard.com/OPTCL From Dt- 01.07.2026 (10.00 AM) to Dt- 21.07.2026 (12.30 PM). Interested bidder may visit OPTCL's official web site <http://www.optcl.co.in> and www.tenderwizard.com/OPTCL for detail specification.

N.B:-All subsequent addendums / corrigendum to the tender shall be hosted in the www.tenderwizard.com/OPTCL only.

Engineer-in-Charge

BharatNet Phase-II Project

NOTICE INVITING TENDER
ODISHA POWER TRANSMISSION CORPORATION LTD.,
REGD. OFFICE: JANPATH, BHUBANESWAR – 751 022,
ODISHA, INDIA.
EIC. BharatNet –e-Tender 2/ 2026-27.

For and on behalf of the ODISHA POWER TRANSMISSION CORPORATION LTD., the undersigned invites bids from manufacturers under two-part bidding system in e- tendering mode only as per the following details.

Tender Specification No.	Sl	Item description	Unit	Quantity	EMD in (Rs)	Cost of tender document in (Rs)	Tender Processing Fee (Rs)	Last date of receipt & opening of tender
Tender 2/ 2026-27. EIC. BharatNet –e-	1	T.Buckle with E-link for cable dia 14mm+/5mm.	Nos	17920	Rs.1,46,228.00 (Bid Security Declaration to be furnished in Annexure-1(A)	Rs.12000 /- + GST @18%= 14,160/-	5000/- (INR)+ GST@ 18%= 5900/-	21.07.2026 (17.30hrs.) & 22.07.2026 (15.00Hrs.)
	2	C.Thimble for cable dia 14mm+/5mm.	Nos	15962				
	3	P.Helix for cable dia 14mm+/5mm.	Nos	11605				
	4	T.Helix for cable dia 14mm+/5mm.	Nos	11605				
	5	UPC with 3 sets of N/B/W and SS304 Split pin duly covered with HSS abrasion protection.	Nos	4851				

The bidder who is a local Micro & small Enterprise (MSE) registered with respective DICs, Khadi, village, cottage & Handicrafts industries and OSIC/NSIC then their EMD will berespectively.

The bidders can view the tender documents from Tender Portal free of cost.

TENDER COST:

The bidders who want to submit bids shall have to pay non-refundable tender cost for the concerned LOT(s) amounting to Rs. 14,160/- (Rupees Fourteen Thousand One Hundred Sixty) Only towards the tender cost **online** through e-payment gateway link provided in e-tender portal (by using Net Banking, Debit Card or Credit Card). They have to also submit notarized hard copy of GST registration certificate on or before the date & time of opening of techno-commercial bid (Part-I). The bidders can also submit Tender Cost as per tender notice, The online payment can be made prior to last date & time of submission of online tender. **The tender cost is exempted for the bidder who is a local Micro & small Enterprise (MSE) registered with respective DICs, Khadi, village, cottage & Handicrafts industries and OSIC/NSIC.**

TENDER PROCESSING FEE:

The bidders shall have to submit non-refundable amount of Rs.5,900/- (Rupees Five thousand nine hundred) only including GST @ 18% towards the tender processing fee to K.S.E.D.C.Ltd, in e-payment mode. The e-payment of above amount is to be made to enable the bidder to down load the bid proposal sheets & bid document in electronic mode.

Earnest Money Deposit (EMD) :

- a) The bidder shall furnish, as part of an Earnest Money Deposit(EMD) of the amount INR as mentioned above in Notice inviting Tender.
- b) The EMD must be submitted in the form of Bank Guarantee valid for a period of 240(Two Hundred Forty) days from the last date of submission of bids as mentioned in original e-tender notice.
- c) The bid security shall be denominated in Indian Rupees only and shall be one of the following forms:
 - i) Crossed Bank Draft/Pay order in favour of DDO,HQRS, Odisha Power Transmission Corporation Ltd. payable at Bhubaneswar, from any schedule Bank.
 - ii) Irrevocable Bank Guarantee issued by any schedule Bank as per prescribed format in favour of “Odisha Power Transmission Corporation Ltd “ en-cashable at Bhubaneswar Branch of the issuing Bank only.

SUBMISSION OF TENDER COST & TENDER PROCESSING FEE & EMD:

The bidder shall deposit the tender cost, tender processing fee and EMD prior to last date & time of opening of bid(Part-I) as notified in tender notice.

The bidders shall scan and upload the same in the prescribed form in .gif or .jpg format in addition to sending the original as stated above. The bidder(s) shall submit Proof of payment of Tender Cost, Tender Processing fees,EMD and shall upload the same in the prescribed attachment in .gif or .jpg format in addition to submitting the original to the undersigned on or before the scheduled date and time for opening of Technical Bid.

The prospective bidders are advised to register their user ID, Password, company ID from website www.tenderwizard.com/OPTCL by clicking on hyper link “Register Me”.

Any clarifications regarding the scope of work and technical features of the tender can be had from the undersigned during office hours.

Minimum qualification criteria of bidders: AS STIPULATED IN SECTION-II, (G.T.C.C) OF THE TENDER SPECIFICATION.

Engineer-in-Charge

BharatNet Phase-II Project

**ODISHA POWER TRANSMISSION CORPORATION LTD.
OFFICE OF THE ENGINEER –IN-CHARGE
BHARATNET PHASE-II PROJECT**

JANAPATH, BHUBANESWAR – 751022

TENDER SPECIFICATION

NO. EIC. BharatNet –e-Tender-2 /2026-27

CONTAINING

PART – I

COMMERCIAL SPECIFICATION :

	<u>Page no.</u>
SECTION – I : INSTRUCTION TO TENDERERS	06
SECTION – II : GENERAL TERMS AND CONDITIONS OF CONTRACT (G.T.C.C.) (COMMERCIAL)	17
SECTION – III : LIST OF ANNEXURES	35

TECHNICAL SPECIFICATION :

SECTION – IV : TECHNICAL SPECIFICATION	58
ANNEXURE-A : Technical Specification of Type-I ADSS ACCESORIES	

<u>PART – II</u> : PRICE BID	72
---	----

PART – I.
COMMERCIAL SPECIFICATION

SECTION – I.
INSTRUCTIONS TO TENDERERS

Clause No.	Title	Page No.
1	Submission of Bids.	7
2	Division of Specification.	8
3	Tenders shall be in two parts.	8
4	Opening of Bids.	9
5	Purchaser's right regarding alteration in Quantities, Tendered.	9
6	Procedure and opening time of tenders.	9
7	Bidder's liberty to deviate from specification.	10
8	Eligibility for submission of bids.	10
9	Purchaser's right to accept/reject bids.	10
10	Mode of submission of tenders.	10
11	Bid Security.	10
12	Validity of the bids.	10
13	Price.	10
14	Revision of Tender Price by Bidders.	11
15	Tenderers to be fully conversant with the clauses of the Specification.	11
16	Documents to accompany Bids.	11
17	Documents/Papers to Accompany PART – II Bid.	12
18	Conditional Offer.	12
19	General.	12
20	Expenses in respect of OPTCL's representative for witnessing the inspection & testing of the offered equipment/materials at the inspection and testing site.	13
21	Litigation/ Arbitration	15
22	Per-bid conference	15
23	Mandatory Electronic Bank Guarantee (e-BG) through NeSL platform.	15

PART – I.

COMMERCIAL SPECIFICATION.

SECTION – I.

INSTRUCTIONS TO TENDERERS

1. Submission of Bids :-

The bidder shall submit the bid in Electronic Mode only i.e www.tenderwizard.com/OPTCL. The bidder must ensure that the bids are received in the specified website of the OPTCL by the date and time indicated in the Tender notice. Bids submitted by telex/telegram will not be accepted. No request from any bidder to the OPTCL to collect the Bids in physical form will be entertained by the OPTCL.

The OPTCL reserves the right to reject any bid, which is not deposited according to the instruction, stipulated above. The participants to the tender should be registered under GST Laws.

1. For all the users it is mandatory to procure the Digital Signatures of Class-III.
2. Contractors / Vendors / Bidders / Suppliers are requested to follow the below steps for Registration:
 - a. Click “Register”, fill the online registration form.
 - b. Pay the amount of Rs. 2360/- through e-payment/DD in favour of K S E D C Ltd Payable at Bangalore.
 - c. Send the acknowledgment copy for verification.
 - d. As soon as the verification is being done the e-tender user id will be enabled.
3. After viewing Tender Notification, if bidder intends to participate in tender, he has to use his e-tendering User Id and Password which has been received after registration and acquisition of DSCs.
4. If any Bidder wants to participate in the tender he will have to follow the instructions given below:
 - a. Insert the PKI (which consist of your Digital Signature Certificate) in your System.
(Note: Make sure that necessary software of PKI be installed in your system).
 - b. Click / Double Click to open the Microsoft Internet Explorer (This icon will be located on the Desktop of the computer).
Go to Start > Programs > Internet Explorer.
 - c. Type www.tenderwizard.com/OPTCL in the address bar, to access the Login Screen.
 - d. Enter e-tender User Id and Password, click on “Go”.
 - e. Click on “Click here to login” for selecting the Digital Signature Certificate.
 - f. Select the Certificate and enter DSC Password.

- g. Re-enter the e-Procurement User Id Password.
5. To make a request for Tender Document Bidders will have to follow below mentioned steps.
 - Click “Un Applied” to view / apply for new tenders.
 - Click on Request icon for online request.
 6. After making the request Bidders will receive the Tender Documents which can be checked and downloaded by following the below steps:
 - Click to view the tender documents which are received by the user.
 - Tender document screen appears.
 - Click “Click here to download” to download the documents.
 7. After completing all the formalities Bidders will have to submit the tender and they must take care of following instructions.
 - Prior to submission, verify whether all the required documents have been attached and uploaded to the particular tender or not.
 - Note down / take a print of bid control number once it displayed on the screen
 8. Tender Opening event can be viewed online.
 9. Competitors bid sheets are available in the website for all.
 10. **For any e-tendering assistant contact help desk number mentioned below.**
 - Bangalore – 080- 40482000.

The participants to the tender should be registered under GST Laws.

2. **Division of Specification :-**

The specification is mainly divided into two parts viz. Part-I & Part-II.

Part-I Consists of

[i] Section-I	Instruction to Tenderers.
[ii] Section-II	General Terms & conditions of contract.
[iii] Section-III	Schedules and forms etc.
[iv] Section-IV	Technical Specification.
Vol-I	TS of TYPE IIIA/IIA ADSS OFC & Accessories
Vol-II	TS of 24F/48F/96F joint closure.

Part-II Consists of

Schedule of prices as per Annexure-V

3. **Tenders shall be in Two Parts :-**

The Tenderers are required to submit the tenders in two parts viz. **Part-I (Techno commercial) & Part-II (Price bid).**

The Tenderers are required to submit the tenders in two parts Part-I, technical and commercial and Part-II “Price Bid”.

4. Opening of Bids :-

- [a] The part-I shall be opened on the date and time fixed by the OPTCL for opening of bids in Electronic mode in presence of such of the Tenderers or their authorized representatives [limited to one person only] on the due date of opening of tender who opt remain present. After scrutiny of the technical particulars and other commercial terms, clarifications, if required, shall be sought for from the bidders. The Tenderers shall be allowed 15 days time for such activity.
- [b] On receipt of technical clarification, the bids shall be reviewed, evaluated and those not in conformity with the technical Specification / qualifying experience, shall be rejected. If any of the technical proposal requires modification to make them comparable, discussion will be held with the participating bidders.

All the responsive bidders shall be given opportunity to submit the revised technical and revised price proposals as a follow up to the clarification (modification if any) on the technical proposals. The qualified bidders shall be given opportunity to submit revised price proposals within 15 days from the date of such discussion or within time frame mutually agreed, whichever is earlier.

- [c] When the revised price proposals are received, the original price proposals will be returned to the bidders unopened along with their original technical proposals. Only the revised technical and price proposals will be considered for bid evaluation. The price bids [Part-II] of such of the Tenderers, whose tenders have been found to be technically and commercially acceptable, including those supplementary revised price bids, submitted subsequently, shall be opened in the presence of the bidder's representative on a date and time which will be intimated to all technically and commercially acceptable Tenderers.
- [d] The bidders are required to furnish sufficient information to the Purchaser to establish their qualification, capacity to manufacture and/or supply the materials/perform the work. Such information shall include details of bidder's experience, its financial, managerial and technical capabilities.
- [e] The price bids of the technically and otherwise acceptable bids shall only be evaluated as per the norms applicable in terms of this Specification.

5. Purchaser's Right Regarding Alteration of Quantities Tendered :-

The Purchaser may alter the quantities of materials at the time of placing orders. Initially the purchaser may place orders for lesser quantity with full freedom to place extension orders for further quantity under similar terms and conditions of the original orders. Orders may also be split among more than one tenderer for any particular item, if considered necessary in the interest of the Purchaser to get the goods earlier.

6. Procedure and opening time of tenders :-

Tenders will be opened in the office of the Chief General Manager [TELECOM] on the specified date and time in presence of the Tenderers or their authorized representatives [limited to one person only] in case of each bidder who may desire to be present, at the time of opening the bids.

7. Bidder's Liberty to deviate from Specification :-

The Tenderer may deviate from the specification while quoting, if in his opinion, such deviation is in line with the manufacturer's standard practice and conducive to a better and more economical offer. All such deviations should however be clearly indicated giving full justifications for such deviation. [Read with Clause-9, Section-II of the Specification].

8. Eligibility for submission of bids :-

Only those manufacturers who have deposited the cost of tender specification are eligible to participate in the tender. They should submit the money receipt as a proof of such payment. The local Micro and small Enterprises (MSEs) **(In the state of Odisha)** based in Odisha and registered with respective DICs, Khadi, Village, Cottage & Handicrafts Industries, OSIC and NSIC can participate without payment of the cost of tender specification

9. Purchaser's right to accept/ reject bids :-

The purchaser reserves the right to reject any or all the tenders without assigning any reasons what so ever if it is in the interest of OPTCL, under the existing circumstances. [Read with clause-10, Section-II of the specification].

10. Mode of submission of Tenders :-

[A] Tenders shall be submitted in electronic mode only.
(www.tenderwizard.com/OPTCL)

[B] **Telegraphic or FAX tenders** shall not be accepted under any circumstances.

11. Bid Security :-

Bidders are to furnish bid security declaration as per the prescribed format at Annexure-I

12. Validity of the Bids :-

The tenders should be kept valid for a period of **180** days from the date of opening of the tender, failing which the tenders will be rejected.

13. PRICE :-

i) Tenderers are requested to quote-'FIRM' Price. No deviation from **FIRM PRICE** will be entertained irrespective of deviation clause No.7 of this part of the specification.

14. Revision of Tender Price by Bidders :-

[a] After opening of tenders and within the validity of period, no reduction or enhancement in price will be entertained. If there is any change in price, the tender shall stand rejected.

[b] After opening of price bid if the validity period is not sufficient to place purchase order, the tenderer may be asked by the purchaser to extend the validity period of the bid under the same terms and condition as per the original tender.

However, the tender are free to change any or all conditions including price except delivery period of their bids at their own risk, if they are asked by the purchaser to extend the validity period of the bid prior to opening of price bid.

15. Tenderers to be fully conversant with the clauses of the Specification : -

Tenderers are expected to be fully conversant with the meaning of all the clauses of the specification before submitting their tenders. In case of doubt regarding the meaning of any clause, the tenderer may seek clarification in writing from the EIC, Bharatnet OPTCL. This, however, does not entitle the Tenderer to ask for time beyond due date, fixed for receipt of tender.

16. Documents to Accompany Bids :-

Tenderers are required to submit tenders in the following manner:

Part-I of the Tender shall Contain the following documents.

- [i] Declaration Form. [As per Annexure-I]
- [ii] Bid security declaration. [As per Annexure-I].
- [iii] Technical specification and Guaranteed Technical Particulars conforming to the Purchaser's Specification along with drawings, literatures and all other required Annexures, duly filled in.
- [iv] Photostat copies of TSEC certificates of materials offered as stipulated in the Technical Specification.
- [v] Abstract of Terms & conditions in prescribed proforma as per **Annexure-II**.
- [vi] General Terms & Conditions of supply offer as per Section-II of the Specification.
- [vii] List of orders executed for similar materials during the period as against "minimum qualification requirement", indicating the customer's name, Purchase Order No. & Date, date of supply and date of commissioning etc.
- [viii] Data on past experience **as per Clause-7 of Section-II** of the Specification.

- [ix] GST Compliance Rating. The GST Identification Number(GSTIN) under GST Laws and permanent account number [PAN] of the firm under Income tax Act are required.
- [x] Audited Balance sheet & profit loss accounts of the bidder, for past (3) three years.
- [xi] Schedule of quantity and delivery in the prescribed Proforma vide Annexure, as appended.
- [xii] List of Orders in hand to be executed.
- [xiii] Deviation schedule.
- (xiv) Local micro & small enterprisers (MSEs) **(In the state of Odisha)** based in Odisha and registered with respective DICs, Khadi, Village, Cottage & Handicrafts Industries, OSIC and NSIC have to submit notarized hard copy of valid registration as local MSE **(In the state of Odisha)** as above on or before the date & time of submission of techno-commercial bid and upload the scan/soft copy of the same in e-tender portal.
- [xv] The bidder should not have any pending litigation or arbitration with OPTCL with regard to any project or related activity. The bidder should certify/declare the same in unequivocal terms by way of an affidavit duly sworn before a magistrate.
- [XVI] Tender specific authorization from the manufacturer of the offered equipment as per Annexure-X.

17. Documents/ Papers to accompany Part-II Bid :-

- (a) Part – II of the tender shall consist of the following
 - (i) Schedule of prices in the prescribed proforma

18. Conditional Offer :-

Conditional offer shall not be accepted.

19. General: -

- (i) In the event of discrepancy or arithmetical error in the schedule of price, the decision of the purchaser shall be final and binding on the Tenderer.
- (ii) For evaluation, the price mentioned in words shall be taken if there is any difference in figures and words in the price bid.
- (iii) Notice inviting tender shall form part of this specification.
- (iv) The price bids of the technically and otherwise acceptable bids shall only be evaluated.
- (v) **Tenderer can offer any lot or all the lots of the tender. But the tender (bid) must be furnished separately for each lot. For each lot, the tenderer has to submit PART-I & PART-II of the bids separately.**

- (vi) It should be distinctly understood that the part-II of the bid shall contain only details/documents relating to price, as outlined in clause-17 mentioned herein above. Inclusion of any of the documents/information etc. shall render the bid liable for rejection.

20. Expenses in respect of OPTCL's representative for witnessing the inspection & testing of the offered equipment/materials at the inspection and testing site:-

The testing and inspection of the materials at manufacturer works are in the scope of work of the Supplier.

OPTCL inspecting officer, on receipt of offer for inspection from the contractor/supplier, proceeds to the manufacturer works to witness the Type/Acceptance/Routine test.

Important:

It is hereby informed to all the bidders that the relevant clauses of the contract specification, pertaining to inspection and testing of equipment/materials, are hereby supplemented with following additional terms and conditions.

The expenses under the following heads, in respect of OPTCL's representative for witnessing the inspection & testing of the offered equipment/materials at the inspection and testing site, shall be borne by the contractor / supplier.

a) Hotel Accommodation :-

- I. Single room accommodation in 4 star hotel for the OPTCL inspecting officer of the rank of Assistant General Manager (Grade E-6) and above.
- II. Single room accommodation in 3 star hotel for the OPTCL inspecting officer of the rank below Assistant General Manager (Grade E-6).

N.B.: It is the responsibility of the contractor to arrange the hotel accommodation matching with their inspection and testing schedule, so that the inspecting officer can check-in the hotel one day prior to the date of inspection and check out after the completion of the inspection, subject to availability of the return travel ticket. In case of extended duration of inspection or non-availability of the return travel ticket, Contractor/supplier/manufacturer shall arrange for the extended stay of the inspecting officer in the Hotel accordingly. In case there is no hotel with prescribed standard in and around the place of inspection, the contractor/supplier/manufacturer shall suggest alternative suitable arrangement at the time of offer for inspection, which is subjected to acceptability of OPTCL inspecting officer.

b) Journey of the inspecting officer :-

- (i) To and fro travel expenditure from the Head Quarters of the inspecting officer to the place of inspection/testing shall be borne by the contractor/supplier/manufacturer. Journey from the Head Quarters of the inspecting officer to the nearest Air Port by train (1st/IIInd A.C) & A/C Taxi then by Air to the place of inspection/testing or to the nearest place of inspection/testing and then by train (1st/IIInd A.C) & A/C taxi to the place of inspection/testing shall be arranged by the contractor/supplier/manufacturer.
- (ii) For train journey, inspecting officer of the rank Assistant General Manager and above shall be provided with 1st class AC ticket and inspecting officer below the rank of Assistant General Manager shall be provided with 2nd class AC ticket.
- (iii) The Air-ticket / train-ticket booking/cancellation is the responsibility of the contractor / supplier.
- (iv) Moreover, if during the journey there is an unavoidable necessity for intermediate travel by road/ waterway/sea-route, the contractor/supplier shall provide suitable conveyance to the inspecting officer for travel this stretch of journey or bear the cost towards this. Any such possibilities shall be duly intimated to OPTCL at the time of their offer for inspection.

c) Local Conveyance:

At the place of the inspection/testing, for local journey of the inspecting officer between Hotel and inspection/testing site and or any other places, Air-conditioned four wheeler vehicle in good condition shall be provided by the contractor/supplier/manufacturer.

d) Following points are also to be considered:

- (i) All the above expenses shall be deemed to be included in the bidder's quoted price for that supply item. Bidder shall not be eligible to raise any extra claim in this regard.
- (ii) Manufacturer may assume that only in 40% of the inspection and testing offer cases, OPTCL inspecting officer, not below the rank of Assistant General Manager will witness the inspection and testing.
- (iii) In case of inspection and testing of materials, OPTCL may depute more than one inspecting officer.
- (iv) Manufacturer shall judiciously plan the inspection/testing schedule and place of inspection/testing, so that optimum number of inspection/testing and minimum time shall be required to cover all the materials of the relevant contract package.

- (v) It shall be the responsibility of the manufacturer to organize the above tour related matters of OPTCL inspecting officer including the matters related to overseas inspection/testing, if any.

21. Litigation/Arbitration:-

- (i) Bidder has to furnish detailed information on any litigation or arbitration arising out of contracts completed or under execution by it over the last five years. A consistent history of litigation by or against the bidder may result in rejection of bid.
- (ii) The bidder should not have any pending litigation or arbitration with OPTCL with regard to any project or related activity. The bidder should certify/declare the same in unequivocal terms by way of an affidavit duly sworn before a magistrate or notary. Bid furnished by the bidder shall not be eligible for consideration if it is not accompanied by the affidavit. Further, the bid/LOA/LOI shall liable for outright rejection/cancellation at any stage if any information contrary to the affidavit/declaration is detected.

22. Pre-Bid conference :-

An online pre-bid meeting shall be held on the **13.07.2026 (11 AM)(online)**. Interested bidders may raise written queries **three days (03)** prior to the pre bid conference, if any, pertaining to this tender package, which shall be clarified during the pre-bid conference and to be uploaded in OPTCL website. The bidders are requested to send their **Email id to eic.bharatnet_ph2@optcl.co.in** before 12.07.2026. **Queries after the dead line as indicated above shall not be entertained.** The detail of VC LINK will be up loaded in tender wizard portal of OPTCL.

23. Mandatory Electronic Bank Guarantee (e-BG) through NeSL Platform:-

- All Bank Guarantees required under this Tender, namely (a) Bid Security (Earnest money Deposit) (b) Performance Security (c) Security against Advance Payment shall be submitted only in the form of Electronic Bank Guarantee (e-BG) issued through National E-Governance Services Limited (NeSL) platform.
- Physical/Paper Bank Guarantees will not be accepted. Any Bid submitted with Physical BG shall be treated as non-responsive and rejected.
- The Bidder shall ensure that the e-BG is issued by any Scheduled Commercial Bank listed on NeSL platform and is delivered electronically to the OPTCL's official NeSL account : Name of the Organization/ Beneficiary : Odisha Power Transmission Corporation Limited, NeSL ID: AAACO7873L
- Procedure for submission:
 - Bidder / Contractor shall request the issuing bank to create and deliver the e-BG directly to the Employer's (OPTCL) NeSL ID

- Upload the e-BG Acknowledgement/Unique Reference Number (URN) against Bid Security / EMD in the Technical bid.
- The Employer (OPTCL) will verify the e-BG instantly on NeSL portal.
- Format, Amount and validity of e-BGs shall be strictly as per Tender specification.
- No charges towards stamping, verification or amendment of e-BG shall be borne by the Employer. All such charges shall be borne by the Bidder/Contractor.
- In case of amendment/extension, the Contractor shall submit the amended e-BG through NeSL platform only.
- A copy of the e-BG against Bid Security / EMD must be uploaded online with the bid documents. A copy of e-BG against Bid Security / EMD with Unique Reference Number (URN) shall also submitted to the office of Chief General Manager (Telecom), OPTCL, 2nd floor, Multistoryed building, HQRS,OPTCL,Janpath, Bhubaneswar-751010 on or before scheduled date & time of opening of Tender.
- Information of Beneficiary required for issuance of Electronic Bank Guarantee (e-BG)
 - i. Name of Beneficiary's Representative – UMESH KUMAR GUPTA
 - ii. Beneficiary Email ID – cgm.tel@optcl.co.in
 - iii. Beneficiary Mobile No. – 9438907259
 - iv. Beneficiary PAN / UIN – AAACO7873L
 - v. Beneficiary Date of Incorporation/Birth – 29-MAR-2004
 - vi. Beneficiary Legal Constitution – ODISHA STATE PUBLIC SECTOR UNDERTAKING
 - vii. Platform – NeSL

.....

SECTION – II.

GENERAL TERMS AND CONDITIONS OF CONTRACT [G.T.C.C.]

Clause No.	Title	Page No.
1	Scope of the contract.	19
2	Definition of terms.	19
3	Manner of execution.	20
4	Inspection and testing.	20
5	Rejection of materials.	21
6	Experience of bidders.	22
7	Language and measures.	22
8	Deviation from Specification.	22
9	Right to reject/accept any tender.	23
10	Supplier to inform himself fully.	23
11	Patent rights etc.	23
12	Delivery.	23
13	Dispatch Instructions.	24
14	Supplier's Default Liability.	24
15	Force Majeure.	24
16	Extension of Time.	25
17	Guarantee Period.	25
18	Bank Guarantee towards Security Deposit, Payment and Performance guarantee	25

Clause No.	Title	Page No.
19	Import License.	26
20	Terms of Payment.	26
21	Price Reduction Schedule	26
22	Insurance.	27
23	Payment Due from the Manufacturer/Supplier.	27
24	Rating under Goods and Services Tax and Balance sheet and profit & Loss Account:	27
25	Certificate of exemption from Goods & Services Tax.	27
26	Supplier's Responsibility.	28
27	Validity.	28
28	Evaluation.	28
29	Minimum qualification criteria of Bidders.	31
30	Jurisdiction of High Court of ODISHA.	32
31	Correspondences.	32
32	Official Address of the Parties to the Contract.	32
33	Outright rejection of Tenders.	32
34	Documents to be treated as confidential.	34
35	Scheme/Projects	34

PART-I
SECTION-II
GENERAL TERMS AND CONDITIONS OF CONTRACT [G.T.C.C.]

1. Scope of the contract:

- 1.1 The scope of the contract shall be the design, manufacture, assembly, inspection and testing at the manufacture's work, packing and delivery F.O.R. (destination) of the materials specified for the respective stations.
- 1.2 **The manufacturer has to dispatch the materials to the designated site. The site wise quantity of materials to be dispatched shall be intimated to the manufacturer/supplier during issue of DI (Dispatch instruction).**

2. Definition of terms:

For the purpose of this specification and General Terms and Conditions of contract [GTCC], the following words shall have the meanings hereby indicated, except where otherwise described or defined.

- 2.1 "The Purchaser" shall mean the Engineer-in-Charge [BharatNet] for and on behalf of ODISHA POWER TRANSMISSION CORPORATION LTD., Bhubaneswar.
- 2.1.1 "The Engineer" shall mean the Engineer appointed by the Purchaser for the purpose of this contract.
- 2.2 "Purchaser's Representative" shall mean any person or persons or consulting firm appointed and remunerated by the Purchaser to supervise, inspect, test and examine materials to be supplied.
- 2.3 "The supplier" shall mean the bidder whose bid has been accepted by the purchaser and shall include the bidder's executives, administrators, successors and permitted assignees.
- 2.4 "Contract Price" shall mean the sum named in or calculated the bid.
- 2.5 "General Condition" shall mean these General Terms and Conditions of Contract.
- 2.6 "The Specification" shall mean both the technical as well as commercial parts of the specification annexed to or issued with GTCC and shall include the schedules and drawings, attached thereto as well as all samples and pattern, if any.
- 2.7 "Month" shall mean "Calendar month".

- 2.8 Writing” shall include any manuscript, type written, printed or other statement reproduction in any visible form and whether under seal or under hand.
- 2.9 Basic Price (Taxable value for Goods) at the point of destination” shall mean the price quoted by the bidder for material at the consignee’s store/site. The cost is inclusive of packing, forwarding, freight, insurance and all expenses and taxes & duties at the end of the supplier excluding Goods & Service Tax. The Goods & Service Tax shall be shown in a separate column item wise alongside the Basic Price quoted at the applicable rate in the Tax Invoice. The applicable rate of GST shall refer to the HSN code of the material supplied. The Basic Price and GST thereon shall be the “FOR Destination Price” as quoted by the bidder.
- 2.10 The term “Contract document” shall mean and include GTCC, specifications, schedules, drawings, form of tender, Notice Inviting Tender, covering letter, schedule of prices or the final General Conditions, any special conditions, applicable to the particular contract.
- 2.11 Terms and conditions not herein defined shall have the same meaning as are assigned to them in the Indian Contract Act, failing that in the Odisha General Clauses Act.

3. Manner of execution:

All the materials supplied under the contract shall be manufactured in the manner, set out in the specification or where not set out, to the reasonable satisfaction of the Purchaser’s representative.

4. Inspection and Testing:

- [i] The purchaser’s representative shall be entitled at all reasonable times during manufacture to inspect, examine and test at the supplier’s premises, the materials and workmanship of all equipment/materials to be supplied under this contract and if part of the said equipment/material is being manufactured in other premises, the supplier shall obtain for the purchaser’s representative permission to inspect, examine and test as if the equipment/material were being manufactured in the contractor’s premises. Such inspection, examination and testing shall not relieve the supplier from his obligations under the contract.
- [ii] The Supplier shall give to the purchaser adequate time/notice (at least clear 15 days for inside the state suppliers and 20 days for outside the state suppliers) in writing for inspection of materials indicating the place at which the equipment/material is ready for testing and inspection and shall also furnish the shop Routine Test Certificate, Calibration certificates of Testing instruments, calibrated in Govt. approved laboratory with authenticity letter of that laboratory along with the offer for inspection. A packing list along with the offer, indicating the quantity which can be delivered in full truck load/Mini truck load to facilitate issue of dispatch instruction shall also be furnished.

- [iii] Where the contract provides for test at the Premises of the supplier or any of his sub-vendors, the supplier shall provide such assistance, labor, materials, electricity, fuel and instruments, as may be required or as may be reasonably demanded by the Purchaser's representative to carry out such tests efficiently. The supplier is required to produce shop routine test Certificate, calibration certificates of Testing Instruments before offering their materials/equipment for inspection & testing. The test house/laboratory where tests are to be carried out must be approved by the Govt. A letter pertaining to Govt. approved laboratory must be furnished to the purchaser along with the offer for inspection.
- [iv] After completion of the tests, the Purchaser's representative shall forward the test results to the Purchaser. If the test results conform to the specific standard and specification, the Purchaser shall approve the test results and communicate the same to the supplier in writing. The supplier shall provide at least five copies of the test certificates to the Purchaser.
- [v] The Purchaser has the right to have the tests carried out at his own cost by an independent agency whenever there is dispute regarding the quality of supply.
- [vi] If the firm fails to present the offered items for inspection/testing as per their inspection call due to any reason(s) during the visit of inspecting officer at the testing site, the firm shall have to bear all expenses towards repetition of inspection and testing of the total offered quantity or part thereof.

5. **Rejection of Materials:**

In the event any of the material supplied by the manufacturer is found defective due to faulty design, bad workmanship, bad materials used or otherwise not in conformity with the requirements of the Specification, the Purchaser shall either reject the equipment/material or ask the supplier in writing to rectify or replace the defective equipment/material free of cost to the purchaser. The manufacturer on receipt of such notification shall either rectify or replace the defective material free of cost to the purchaser within 15 days from the date of issue of such notification by the purchaser. If the supplier fails to do so, the Purchaser may:-

- [a] At its option replace or rectify such defective materials and recover the extra costs so involved from the manufacturer plus fifteen percent and/or.
- [b] Terminate the contract for balance work/supplies, with enforcement of penalty Clause as per contract for the un-delivered goods and with forfeiture of Performance Guarantee/ Composite Bank guarantee.
- [c] Acquire the defective materials at reduced price, considered equitable under the circumstances.

6. Experience of Bidders:

The bidders should furnish information regarding experience particularly on the following points:

- [i] Name of the manufacturer/ Supplier
- [ii] Standing of the firm and experience in manufacture of material quoted:
- [iii] Description of material similar to that quoted, supplied and installed during the last two years with the name(s) of the Organizations to whom supplies were made wherein, at least one (1) certificate shall be from a state/central P.S.U.
- [iv] Details as to where installed etc.
- [v] Testing facilities at manufacturer's works.
- [vi] If the manufacturer is having collaboration with another firm [s], details regarding the same.
- [vii] A list of purchase orders of identical material offered as per technical specification executed during the last two years along with users certificate. User's certificate shall be legible and must indicate, user's name, address, designation, place of use, and satisfactory performance of the equipment/materials for at least two years from the date of commissioning. Wherein at least one (1) certificate shall be from a State/Central or P.S.U. Bids will not be considered if the past manufacturing experience is found to be un-satisfactory or is of less than 2 (two) years on the date of opening of the bid and bids not accompanying user's certificate will be rejected.

7. Language and measures:

All documents pertaining to the contract including specifications, schedule, notices, correspondence, operating and maintenance instructions, drawings or any other writing shall be written in English language. The metric system of measurement shall be used exclusively in this contract.

8. Deviation from specification:

It is in the interest of the tenderers to study the specification, specified in the tender schedule thoroughly before tendering so that, if any deviations are made by the Tenderers,(both commercial and Technical), the same are prominently brought out on a separate sheet under heading "Deviations Commercial" and "Deviations Technical".

A list of deviations shall be enclosed with the tender. Unless deviations in scope, technical and commercial stipulations are specifically mentioned in the list of deviations, it shall be presumed that the tenderer has accepted all the conditions, stipulated in the tender specification, notwithstanding any exemptions mentioned therein.

9. **Right to reject/accept any tender:**

The purchaser reserves the right either to reject or to accept any or all tenders if the situation so warrants in the interest of the purchaser. Orders may also be split up between different Tenderers on individual merits of the Tenderer. The purchaser has exclusive right to alter the quantities of materials/ equipment at the time of placing final purchase order. After placing of the order, the purchaser may defer the delivery of the materials. It may be clearly understood by the Tenderer that the purchaser need not assign any reason for any of the above action [s].

10. **Supplier to inform himself fully:**

The supplier shall examine the instructions to tenderers, general conditions of contract, specification and the schedules of quantity and delivery to satisfy himself as to all terms and conditions and circumstances affecting the contract price. He shall quote price [s] according to his own views on these matters and understand that no additional allowances except as otherwise provided there in will be admissible. The purchaser shall not be responsible for any misunderstanding or incorrect information, obtained by the supplier other than the information given to the supplier in writing by the purchaser.

11. **Patent rights Etc.**

The manufacturer shall indemnify the Purchaser against all claims, actions, suits and proceedings for the infringement of any patent design or copy right protected either in the country of origin or in India by the use of any equipment supplied by the manufacturer. Such indemnity shall also cover any use of the equipment, other than for the purpose indicated by or reasonably to be inferred from the specification.

12. **Delivery:**

- [a] Time being the essence of the contract; the material shall be supplied within the delivery period, specified in the contract. The Purchaser, however, reserves the right to reschedule the delivery and change the destination if required. The delivery period shall be reckoned from the date of placing the Letter of Intent/Purchase order, as may be specified in LOI/Purchase order.
- [b] The desired delivery period shall be as indicated at Appendix-II (Quantity & Delivery Schedule) of Section-IV (Technical Specification).

13. **Dispatch instructions.**

I] The materials should be securely packed and dispatched directly to the specified site at the supplier's risk by Road Transport only.

II] **Loading & unloading of Ordered Materials.**

It will be the sole responsibility of the supplier for loading and unloading of materials both at the factory site and at the destination site/store.

The Purchaser shall have no responsibility on this account.

14. **Supplier's Default Liability.**

[i] The Purchaser may, upon written notice of default to the supplier, terminate the contract in circumstances detailed hereunder.

[a] If in the judgment of the Purchaser, the supplier fails to make delivery of equipment/material within the time specified in the contract or within the period for which if extension has been granted by the Purchaser in writing in response to written request of the supplier.

[b] If in the judgment of the Purchaser, the supplier fails to comply with any of the provisions of this contract.

[ii] In the event, Purchaser terminates the contract in whole or in part as provided in Clause-15 (I) of this section, the Purchaser reserves the right to purchase upon such terms and in such a manner as he may deem appropriate in relation to the equipment/material similar to that terminated and the supplier will be liable to the Purchaser for any additional costs for such similar equipment/material and/or for penalty for delay as defined in clause-22 of this section until such reasonable time as may be required for the final supply of equipment.

[iii] In the event the Purchaser does not terminate the contract as provided in clause 15(I) of this Section, supplier shall be liable to the Purchaser for penalty for delay as set out in Clause-22 of this section until the equipment is accepted. This shall be based only on written request of the supplier and written willingness of the Purchaser.

15. **Force Majeure:**

The manufacturer shall not be liable for any penalty for delay or for failure to perform the contract for reasons of force majeure such as acts of god, acts of the public enemy, acts of Govt., Fires, floods, epidemics, Quarantine restrictions, strikes, Freight Embargo and provided that the supplier shall within Ten (10) days from the beginning of delay on such account notifies the purchaser in writing of the cause of delay. The purchaser shall verify the facts and grant such extension, if facts justify.

16. **Extension of time:**

If the delivery of material is delayed due to reasons beyond the control of the supplier, the supplier shall without delay give notice to the purchaser in writing of his claim for an extension of time. The purchaser on receipt of such notice may or may not agree to extend the contract delivery date as may be reasonable but without prejudice to other terms and conditions of the contract.

17. **Guarantee period:**

[i] The stores covered by this specification should be guaranteed for satisfactory operation and against defects in design, materials and workmanship for a period of at least 12 [twelve] months from the date of delivery at site. The above guarantee certificate shall be furnished in triplicate to the purchaser for his approval. Any defect noticed during this period should be rectified by the supplier free of cost to the purchaser provided such defects are due to faulty design, bad workmanship or bad materials used, within one month upon written notice from the purchaser failing which provision of clause 22 (ii) shall apply.

[ii] Equipment/material failed or found defective during the guarantee period shall have to be guaranteed after repair/replacement for a further period of 36 months from the date of commissioning after such repair/replacement. The Bank Guarantee is to be extended accordingly. Date of delivery as used in this clause shall mean the date on which the materials are received in OPTCL'S stores/site in full & good condition which are released for dispatch by the purchaser after due inspection.

18. **B.G. towards security deposit, 100% payment and performance guarantee:**

[i] **For manufacturers situated Inside & out side the state of Odisha.**

A Composite Bank Guarantee (e-BG) as per the Proforma enclosed at Annexure-VII of the specification for 10% (Ten percent) of the Total Landing cost (Taxable Value plus GST thereon) of the purchase order (In case of successful bidder who is a local Micro and small Enterprise (MSEs) registered with respective DICs, Khadi, Village, Cottage & Handicrafts Industries, OSIC and NSIC 5% (Five percent), shall be furnished from any nationalized/scheduled bank having a place of business at Bhubaneswar, to the office of Chief General Manager [Telecommunication] OPTCL within 15 days from the date of issue of the purchase order,. The BG shall be executed on non judicial stamp paper worth of Rs.29.00 [Rupees twenty nine] only or as per the prevalent rules, valid for a period of 14 months from the last date of stipulated delivery period, for scrutiny and acceptance, failing which the supply order will be liable for cancellation without any further written notices. The BG should be accompanied by a confirmation letter from the concerned bank and should have provision for encashment at Bhubaneswar, before the Bank Guarantee is accepted and all concerned intimated. The B.G should be revalidated as and when intimated to you to cover the entire guarantee period.

[ii] No interest is payable on any kind of Bank Guarantee.

- [iii] In case of non-fulfilment of contractual obligation, as required in the detailed purchase order/Specification, the composite Bank guarantee shall be forfeited.

19. Import License:

In case imported materials are offered, no assistance will be given for release of Foreign Exchange. The firm should arrange to import materials from their own quota. Equipment of indigenous origin will be preferred.

20. Terms of Payment:

i) 90% taxable value of each consignment with 100% Goods and Services Tax in full as applicable will be paid on receipt of materials in good condition at stores/desired site and verification thereof, subject to furnishing and approval of

(a) Contract cum Performance Bank Guarantee (e-BG) at the rate of 10%(Ten percent) of Taxable Value plus GST thereon.

(b) Guarantee certificate, Test certificate by the Purchaser.

ii) TDS under GST Laws for intra state transactions shall be deducted as applicable.

iii) Any imposition of new tax or revision of tax shall be paid/reimbursed at the time of dispatch, scheduled or actual whichever is lower (i.e. If delivery is within schedule period, tax variation as applicable shall be paid, and if delivery is made beyond schedule date, any additional financial implication due to statutory variation in tax shall be to bidder's account)

Balance 10% of the taxable value of the equipment, shall be paid after completion of the guarantee period.

21. Price Reduction Schedule:

Price Reduction Schedule for Delay in Completion of Supply under Purchase Order/Contract

(i) If the Supplier fails to deliver the materials within the delivery schedule, specified in the Purchase Order/Contract including delivery time extension, if any, granted with waiver of Price Reduction Schedule, the Purchaser shall recover from the Supplier, Price Reduction Schedule for a sum of half per cent (0.5 per cent) of the Taxable Value of the un-delivered equipment /materials/uncompleted portion for each calendar week of delay or part thereof. For this purpose, the date of receipted challan shall be reckoned as the date of delivery. The total amount of Price Reduction Schedule shall not exceed five per cent (5%) of the Taxable Value of the un-delivered equipment/materials/erection. Equipment will be deemed to have been delivered only when all its components, accessories and spares as per technical Specification are also delivered. If certain components, accessories and spares are not delivered in time, the equipment/materials will be considered delayed until such time as the missing components, accessories and spares are delivered.

(ii) During the guarantee period, if the Supplier fails to rectify/replace the material within 30 days from the date of intimation of defect by the purchaser, then the Price Reduction Schedule at the rate of half percent (0.5%) of the Total Taxable Value for each calendar week of delay or part thereof shall be recovered by the purchaser. For this purpose, Price Reduction Schedule shall be reckoned from the 30th day from the date of issue of letter on defectiveness of equipment/material/installation. The total amount of Price Reduction Schedule in this case shall not exceed 10% (TEN PERCENT) of the Purchase Order/Contract amount except GST (i.e.Total Taxable Value). If the defects, so intimated are not rectified or

equipment/materials not replaced by the supplier within the guarantee period, then whole of the C.P.B.G. will be forfeited by the purchaser, without any intimation to the supplier.

22. **Insurance:**

The Supplier shall undertake insurance of stores covered by this Specification unless otherwise stated. The responsibility of delivery of the stores at destination in good condition rests with the Supplier. Any claim with the Insurance Company or transport agency arising due to loss or damage in transit has to be settled by the supplier. The Supplier shall undertake free replacement of materials damaged or lost, which will be reported by the consignee within 30 days of receipt of the materials at destination without awaiting for the settlement of their claims with the carriers and underwriters.

23. **Payment Due from the Manufacturer/Supplier :**

All costs and damages, for which the supplier is liable to the purchaser, will be deducted by the purchaser from any money, due to the manufacturer, under any of the contract (s), executed with OPTCL.

24. **Rating under Goods and Services Tax and Balance sheet and profit & Loss Account:**

The following documents are to be submitted at the time of Tender

Submission:

- i. Compliance rating under Goods and Services Tax for immediate preceding financial _____ year.
- ii. Audited Balance Sheet and Profit & Loss Account of the bidder for the previous three years to assess the financial soundness of the bidder(s).
- iii. GST registration certificate and PAN Card Copy.
- iv. Tax holiday/exemption certificate under GST or any other Act.
- v. TDS exemption certificate under the Income Tax Act or any other act.

25. **Certificate of Exemption from Goods and Services Tax:**

Offers with exemption from Goods and Services Tax shall be accompanied with authenticated attested Photostat copy of exemption certificate. Any claim towards Goods and Services Tax shall be paid on actual basis subject to payment of GST by the supplier. In case Outward supply details of the supplier of Goods in GSTR-1 do not match with GSTR -2 of OPTCL on GSTN portal, the same will be adjusted through debit/credit advice issued by OPTCL

under intimation to the supplier after allowing cooling period of 3 months after the date of supply.

26. Supplier's Responsibility:

Notwithstanding anything mentioned in the Specification or subsequent approval or acceptance by the Purchaser, the ultimate responsibility for design, manufacture, materials used and satisfactory performance shall rest with the Tenderers. The Supplier(s) shall be responsible for any discrepancy noticed in the documents, submitted by them along with the bid(s).

27. Validity:

Prices and conditions contained in the offer should be kept valid for a minimum period of **180** days from the date of opening of the tender, failing which the tender shall be rejected.

28. EVALUATION:

(I) Evaluation of bids will be on the basis of the FOR DESTINATION PRICE (By Road Transport) including Goods and Services Tax & other levies as may be applicable. The FORD PRICE shall consist of the following components

- a) Taxable value of materials
- b) Goods and Services Tax
- c) Other levies.
- d) Any other items, as deemed proper for evaluation by the purchaser.
- e) Loading factors will be taken in to account during evaluation if the prices of some of the items, not quoted.
- f) Any imposition of new tax or revision of tax shall be considered at the time of price bid evaluation.

(II) **e-Reverse Auction is hereby incorporated in the referred tender as follows:**

STRATEGY FOR E-REVERSE AUCTION	
1	Bidders are required to go through the guide lines given below and submit their acceptance to the same.
2	e-Reverse Auction (RA) will be conducted in e-tender portal of OPTCL on

	specified date and time, while bidders shall quote from their own offices/places of their choice. Internet connectivity shall be ensured by the respective agencies/bidders themselves.
3	Demonstration/ training (if not trained earlier) of bidder's nominated person(s), shall be done to explain all the rules related to e-Reverse Auction/ Business Rule document to be adopted.
4	The strategy to be used for reverse auction shall be "DYNAMIC TEMPLATE BIDDING"
Procedure for electronic Reverse Auctioning (e-RA):	
5	<p>a. The e-RA shall be conducted on www.tenderwizard/OPTCL.com only.</p> <p>b. Bidder has to submit letter towards agreement to the Process related Terms & Conditions for e-Reverse Auction, as per (Reverse Auction Process Compliance Form at Annexure-IB). In non-receipt of the same, vendors will not be allowed to participate in e-RA.</p> <p>c. e-RA shall be carried out after opening of Price bids and completion of Price bid evaluation, which will be intimated only to the techno-commercially qualified bidders by OPTCL as per procedure given below.</p> <p>d. OPTCL reserves the right to conduct e-RA and it is obligatory on part of bidder(s) invited to participate in e-RA process once they have responded to the techno-commercial bid.</p>
6	<p>Prior intimation/ Notice for RA invitation will be given to techno-commercially qualified bidders regarding the date & time of opening of the e-RA.</p> <p>The start bid price (SBP) for e-Reverse Auction of each bidder under a particular package shall be the L1 evaluated price for the subject package including Taxes & Duties for the total scope for subject Package. Taking the above discovered L1 price as the upper limit e-RA will be conducted to determine the lowest possible price.</p> <p>Reverse Auction will be conducted amongst first 50% of the technically qualified bidders arranged in order of prices from lowest to highest, as L1, L2,L3-----Ln, and L1 price will be discovered. Minimum of 3 bidders shall be eligible for e RA. (eg. If 4 bidders are financially evaluated then the L1, L2 and L3 bidders shall be eligible for e-RA). Number of bidders eligible for participating in RA would be rounded off to next higher integer value if number of technically qualified bidders is odd (e.g. if 7 bids are technically qualified, then RA will be conducted amongst L1 to L4).</p> <p>However, in case only two bidders are found to be responsive, e-RA would be carried out with both the parties without any elimination. However, OPTCL reserves the right to invite the evaluated L1 bidder for negotiation without conducting the e-RA.</p> <p>In case of price submitted by any bidder is found to be abnormal, OPTCL reserves the right to reject the bid of the bidder(s) .</p> <p>Rank of bidders would be displayed as per the total cost to OPTCL, i.e including Taxes and Duties payable by OPTCL as per the provisions of the bidding document & after e-RA process is over.</p>
7	<p>Names of bidders/ vendors shall not be disclosed during the e-RA process. Names of bidders/ vendors shall be anonymously masked in the e-RA process.</p> <p>(i) In case of RA, start/ reference price and step value of decrement shall be indicated to the bidders at the start of the auction. Any participating bidder can</p>

	<p>bid one or multiple step decrement lower than the prevailing lowest bid at that time. The Bidder shall be able to view Bid Start Price, Bid Decrement Value, Prevailing Lowest Bid value, last Bid Placed by him and time left for bidding.</p> <p>(ii) The step value of decrement in a package to be offered by bidder (the minimum amount of reduction in the total bid price including all taxes & duties during auction), shall be kept at 0.15% of L1 bidder's final evaluated price (or) at approved amount as decided by OPTCL.</p> <p>(iii) Bidders can only quote any value lower than their previous quoted price. However, at no stage, increase in Price will be permissible.</p> <p>(iv) At any point during Reverse Auction, bidding Price field shall remain enabled for the bidders. The reverse auction period shall be unlimited and the initial auction period (1st slot) will be of thirty (30) minutes with provision of auto extension by (10) ten minutes from the schedule/ extended closing time. If any fresh lower bid is received in last ten minutes of initial auction period or extended auction period, the auction shall get extended automatically for another 10 minutes. In case, there is no bid received during schedule/extended slot, the auction shall get closed automatically without further extension.</p> <p>(v) However, bidders are advised not to wait till the last minute or last few seconds to enter their bid during the period of e-reverse auction to avoid complication related with internet connectivity, network problem, system crash down, power failure etc.</p>
8	<p>After conclusion of e-Reverse Auction i.e (Closing Price in Reverse Auction will be taken as offered price by the L1 bidder), decrease in price of individual head of the template shall be considered proportionately on all individual line items of the respective head of the price schedule of the successful L1 bidder .</p> <p>Any bid received at the tender wizard server end subsequent to closure of the e-RA shall be summarily rejected and shall not be considered as a valid bid under whatsoever circumstances. For this purpose, tender wizard server log shall prevail.</p> <p>The bidder shall not involve himself or any of his representatives in price manipulation of any kind directly or indirectly by communicating with other bidders.</p> <p>During Reverse Auction, If no bid is received within the specified time, OPTCL, at its discretion, may decide to close the reverse auction process/ proceed with conventional mode of tendering [Evaluation of Part-II (price bid) submitted by bidders earlier].</p>
9	<p>Consequent upon completion of e-Reverse Auction, OPTCL's decision on award of contract shall be final and binding on the bidders.</p> <p>OPTCL shall be at liberty to call the L1 bidder for further process/ negotiation and also at liberty to cancel the e-reverse auction process/ re-tender at any time, without assigning any reason thereof. OPTCL can decide to reschedule or cancel any reverse auction: the bidders shall be informed accordingly.</p> <p>OPTCL/ Service Provider shall not have any liability to bidders for any interruption or delay in access to the e-Tender site/ Reverse Auction link irrespective of the cause.</p>

(III) Weightage shall be given to the Following factors in the Evaluation & Comparison of Bids.

In comparing bids and in making awards, the Purchaser will consider other factors such as compliance with Specification, minimum qualification criteria as per clause-30, outright rejection of tenders

clause-34 of this tender, relative quality, adaptability of Supplies or services, experience, financial soundness, record of integrity in dealings, performance of materials/equipment earlier supplied, ability to furnish repairs and maintenance services, the time of delivery, capability to perform including available facilities such as adequate shops, plants, equipment and technical organization.

- (IV) The local MSE (**In the state of Odisha**) bidders, based in Odisha, shall be required to furnish their willingness to match their bid price with that of the lowest evaluated bidder without any price preference and in case they agree, they shall be eligible to get up to **30%** of the tendered quantity to be distributed suitably among the willing MSE bidders failing which the said **30%** of the tendered quantity be awarded to the lowest evaluated bidder.

29. Minimum Qualification Criteria of Bidders:

All the prospective bidders are requested to note that their bids for tendered equipment can only be considered for evaluation if:

- i) The bidder should have manufacturing experience of tendered quantity for a minimum period of 2(two) years and the materials should have been manufactured in India at least since last 2(two) years as on the original date of opening of the techno-commercial bid”.
- ii) At least 50% of the tendered quantity should have been supplied within last 5 (Five) years as on the original date of opening of the techno-commercial bid.
- iii) The above materials should have at least 2 (two) years successful performance from the date of commissioning as on the original date of opening of the techno-commercial bid. At least one of the performance certificates shall be submitted from Govt. of India/State Govt.(s) or their undertakings.
- iv) The equipment should have been type tested in NABL India within five years from the original date of opening of the techno-commercial bid.
- (v) Any bidder from a country which shares a land border with India will be eligible to bid in this tender only if the bidder is registered with the Competent Authority as per the requirement of Govt. of India.
- (vi) The bidder should submit self-certification under preference to make in India order in line with Govt. public procurement order no. P-45021/2/2017-PP (BE-II) dated 04.06.2020 and its amendments.
- (vii) “Bidder” (including the term ‘tenderer’, ‘consultant’ or ‘service provider’ in certain contexts) means any person or firm or company, including any member of a consortium or joint venture (that is an association of several persons, or firms or companies), every artificial juridical person not falling in any of the descriptions of bidders stated herein before, including any agency branch or office controlled by such person, participating in a procurement process.
- (viii) “Bidder from a country which shares a land border with India” for the purpose of this Order means :-
 - a. An entity incorporated, established or registered in such a country ; or
 - b. A subsidiary of an entity incorporated, established or registered in such a country ‘ or
 - c. An entity substantially controlled through entities incorporated , established or registered in such a country ; or

- d. An entity whose beneficial owner is situated in such a country ; or
 - e. An Indian (or other) agent of such an entity ; or
 - f. A natural person who is a citizen of such a country ; or
 - g. A consortium or joint venture where any member of the consortium or joint venture falls under any of the above.
- (ix) The beneficial owner for the purpose of (iii)(d) above will be as under :
In case of a company or Limited Liability Partnership, the beneficial owner is the natural person(s), who, whether acting along or together, or through one or more juridical person, has a controlling ownership interest or who exercises control through other means.
- (x) An Agent is a person employed to do any act for another, or to represent another in dealings with third person.
[A] Certificate (to be furnished in bidder's letter head)

I have read the clause regarding restrictions on procurement from a bidder of a country which shares a land border with India; I certify that this bidder is not from such a country or, if from such a country, has been registered with the Competent Authority. I hereby certify that this bidder fulfils all requirements in this regard and is eligible to be considered. [Where applicable, evident of valid registration by the Competent Authority shall be attached.]

30. Jurisdiction of the High Court of Odisha:

`Suits, if any, arising out of this contract shall be filed by either Party in a court of Law to which the jurisdiction of High court of Odisha extends.

31. Correspondences:

- i) Any notice to the supplier under the terms of the contract shall be served by Registered Post or by hand at the Supplier's Principal Place of Business.
- ii) Any notice to the Purchaser shall be served at the Purchaser's Principal Office in the same manner.

32. Official Address of the Parties to the Contract:

The address of the parties to the contract shall be specified:-

- [i] **Purchaser:** Engineer-in-Charge BharatNet Phase II Project, OPTCL
Bhubaneswar-751022 (Odisha)
Email id: eic.bharatnet_ph2@optcl.co.in
Cell No. 9438907447
- [ii] **Supplier:** Address
Cell No.
Fax No.

33. Outright Rejection of Tenders:

Tenders shall be out rightly rejected if the followings are not complied with.

- [i] The tenderer shall submit the bid in electronic mode only and shall submit the tender cost on or before the date and time of submission of technical bid. . In case of local Micro and small Enterprises(MSEs) **(In the state of Odisha)**,

based in Odisha & registered with respective DICs, Khadi, Village, Cottage & Handicrafts Industries, OSIC and NSIC participating in the tender they have to submit notarized hard copy of valid registration as local MSE as above on or before the date and time of submission of technical bid.

- [ii] The tenderer shall submit the bid in electronic mode only
- [iii] The Tender shall not be submitted telegraphically or by FAX.
- [iv] The Tender shall be kept valid for a minimum period of 180 days from the date of opening of tender.
- [v] The Tender shall be submitted in two parts as specified.
- [vi] The Tenders shall be accompanied by a list of major supplies made prior to the date of opening of tender. Data of at least 2 (two) years shall be furnished.
- [vii] The tenderer shall upload the scanned copy of latest type test certificates (for the tests, carried out on the tendered equipment, being offered). Such type tests should have been conducted within last five years from the date of opening of this tender in a Government approved laboratory/CPRI in presence of any Government Organization's representative(s).
- [viii] The schedule of prices should be filled up fully to indicate the break-up of the prices including taxes and duties. Incomplete submission of this schedule will make the tender liable for rejection. Vide Clause-4(ii) of Part-II.
- [ix] The Tenderer should quote 'FIRM' price only and the price should be kept valid for a minimum period of 180 days from the date of opening of the tender.
- (x) The tenderer shall upload the scanned copy legibly written user's certificate to prove the satisfactory operation of the offered equipment /materials for a minimum period of 2 years from the date of commissioning/use as per the tender specification. User's certificate shall include the detailed address of the user with Material, Name and type as per this specification, number of years of satisfactory use/operation & date of issue of this user's certificate with official seal written in English only & clearly visible must be furnished. At least one of the user's certificates shall be from state or Central Govt. or their Undertakings.
- (xi) Guaranteed Technical particulars & Abstract of terms and Conditions should be filled in completely.
- (xii) (a) Detailed information on any litigation or arbitration arising out of contract completed or under execution by it over the last five years. A consistent history of litigation by or against the bidder may result in rejection of bid.

- (b) The bidder should not have any pending litigation or arbitration with OPTCL with regard to any project or related activity. The bidder should certify / declare the same in the unequivocal terms by way of an affidavit duly sworn before a magistrate. Bid furnished by the bidder shall not be eligible for consideration if it is not accompanied by the affidavit. Further the bid / LOA/ LOI shall be liable for outright rejection/ cancellation at any stage if any information contrary to the affidavit / declaration is detected.

34. **Documents to be treated as confidential:**

The supplier shall treat the details of the specification and other tender documents as private and confidential and these shall not be reproduced without written authorization from the Purchaser.

35. **Scheme/Projects:**

The materials covered in this specification shall come under “Govt. of India funded Project “

SECTION – III
[LIST OF ANNEXURES]

The following schedules and proforma are annexed to this specification and contained in Section-III as referred to in the relevant clauses.

Sl. No.	Title	Annexure No.	Page No.
1	Declaration form	ANNEXURE-I(A)	36
2	Reverse Auction Process Compliance Form	ANNEXURE-I(B)	37
3	Abstract of terms and conditions to accompany Section-II of Part-I	ANNEXURE-II	38
4	Schedule of Quantity and Delivery	ANNEXURE-III	38
5	Abstract of price component [to accompany Part-II of this specification]	ANNEXURE-IV	39
6	Schedule of prices to accompany Part-II	ANNEXURE-V	39
7	Bank Guarantee form for earnest money deposit	ANNEXURE-VI	40
8	Composite Bank Guarantee form for security deposit, payment and performance	ANNEXURE-VII	44
9	Chart showing particulars of Earned money deposit furnishable by Tenderers	ANNEXURE – VIII	48
10	Data on Experience.	ANNEXURE – IX	49
11	Schedule of spare parts for five years of normal Operation & Maintenance	ANNEXURE-X	50
12	Schedule of Installations.	ANNEXURE-XI	51
13	Schedule of deviations (Technical)	ANNEXURE-XII(A)	52
14	Schedule of deviations (Commercial)	ANNEXURE-XII(B)	52
15	Litigation/Arbitration	ANNEXURE-XIII	52
16	Affidavit Of Bidder	ANNEXURE-XIV	53
17	Format for extension of Bank guarantee	ANNEXURE-XV	54
18	Tender specific authorization from the manufacturer of the offered equipment.	ANNEXURE-XVI	56
17	DPIIT Certificate	ANNEXURE-XVII	57

ANNEXURE – I(A)

DECLARATION FORM

To

The Engineer-in-Charge, BharatNet Phase-II Project
OPTCL Head Qrs.BBSR,751022

Sub:- Tender Specification No-_____

Sir,

1. Having examined the above specification together with terms & conditions referred to therein * I/We the undersigned hereby offer to supply the materials covered therein complete in all respects as per the specification and General conditions, at the rates, entered in the attached contract schedule of prices in the Tender.
2. * I/We hereby undertake to have the materials delivered within the time specified in the Tender.
3. * I/We hereby guarantee the technical particulars given in the Tender supported with necessary reports from concerned authorities.
4. * I/We certify to have submitted the bid electronically by remitting *cash/money order/D.D./ remitting the cost of tender, herewith and this has been acknowledged by your letter/ money receipt No. Dated,
5. In the event of Tender, being decided in *my/our favour, * I/We agree to furnish the Composite B.G. in the manner, acceptable to ORISSA POWER TRANSMISSION CORPORATION LTD., and for the sum as applicable to *me/us as per clause-19 of section-II of this specification within 15 days of issue of letter of intent/purchase order failing which *I/We clearly understand that the said letter of Intent/Purchase order will be liable to be withdrawn by the purchaser.

Bid Security Declaration

*I/We further declare that, we will not modify/withdraw the bid after opening of techno-commercial bid(i.e. part-I bid) during its validity period and in such an event we agree that OPTCL would be free to debar us from participating in the tenders floated by OPTCL for a period of three years .

Signed this day of 2022

Yours faithfully

Signature of the Bidder with seal of the company

[This form should be dully filled up by the Bidder and uploaded at the time of submission of tender.]

* (Strikeout whichever is not applicable)

EIC.BharatNet –e-Tender-BharatNet-2/2026-27

(Annexure-I B)

(Reverse Auction Process Compliance Form)

(To be submitted on letter head of the bidding company with sign and stamp and along with Technical bid)

To,

EIC, BharatNet Project OPTCL, Bhubaneswar-751010, Odisha

Sub : Agreement to the Process related Terms & Conditions for e-Reverse Auction.

Dear Sir,

This letter is to confirm that:

- The undersigned is authorized representative of the company.
- We have studied the Commercial Terms and the Business rules governing the Reverse Auction as mentioned in your tender and confirm our agreement to that.
- We also confirm that we have gone through the auction manual and have understood the functionality of the same thoroughly.
- We, hereby, confirm that we will honour the Bids placed by us during the tendering/ e- Reverse auction process as called as e-RA.
- We also confirm that we will accept our Rank / Position that will be displayed when the Bidding Time for the Online Reverse Auction is over.

With regards,

Signature with Designation

(with company seal Name &
Address)

(Person having power of attorney for the subject package)

ANNEXURE-II

ABSTRACT OF GENERAL TERMS AND CONDITIONS OF CONTRACT [COMMERCIAL] TO ACCOMPANY SECTION-II PART-I

(To be filled up by the tenderer as indicated in the excel sheet for “ABSTRACT OF PRICE COMPONENT & OTHER COMMERCIAL ASPECTS”)

ANNEXURE-III

SCHEDULE OF QUANTITY AND DELIVERY

(To be filled up by the tenderer)

Sl No	Description	UOM	Quantity required	Desired Delivery,	Destination	Remarks
1	24F Metal Free Type IIIA ADSS OFC.	KM	428	01 Months from the date of LOA	Any store/site of OPTCL	
2	48F Metal Free Type IIIA ADSS OFC.	KM	84	-Do-	-do-	
3	96F Metal Free Type IIIA ADSS OFC.	KM	48			

Signature of Tenderer
with seal of Company

ANNEXURE-IV

(Abstract of price component)

(To be filled up by the tenderer as indicated in the excel sheet)

NB:- Abstract of price component shall be done for equipment/material offered, for installation, testing & commissioning charges, if any. All the above prices will be taken during bid price evaluation.

ANNEXURE-V.

Schedule of prices to accompany Part-II

Item No.	Description.	Qty (unit)	Unit Taxable Value at destination store/ site .	Unit GST	Unit landing Cost including All taxes & Duties.	Total landing cost Including all taxes & duties.
1.	2.	3.	4.	5.	6= (4+5)	7= (6*3)

Signature of Tenderer

Name, Designation and Seal

NB: -

1. The tenderer should fill up the price schedule properly in excel file in e-tender mode. The tender will be rejected, if the price bid is not submitted in accordance with the price schedule. No post tender correspondence will be entertained on break-up of prices. Also, the supplier should agree for delivery at the desired site.
2. The Tenderer shall give an undertaking in part-I of the bid that, entire implication of lower tax and input tax credit benefit have been fully passed on to the purchaser as per anti-profiteering and other provisions under GST Laws while quoting the tender price.
3. Conditional offers will not be acceptable.
4. The bidder is to clearly indicate the period up to which the tax holidays are available to them.
5. Price bid in any other format will not be acceptable and the offer will be rejected.
6. All the above charges will be taken into account, during bid price evaluation.

ANNEXURE-VI

PROFORMA FOR BANK GUARANTEE FORM FOR EARNEST MONEY DEPOSIT

~~(To be Stamped in accordance with Stamp Act and the Non-Judicial Stamp Paper of appropriate value should be in the name of Issuing Bank)~~

Ref No:
e-Bank Guarantee No.
Date:.....

e-BG Amount:.....

Validity Period:.....

This Guarantee Bond is executed this..... day of by us the..... Bank at , P.O..... , Dist....., State..... and Code No.....

Whereas the ODISHA POWER TRANSMISSION CORPORATION Limited, Janpath, Bhubaneswar, a company constituted under the Companies Act-1956 (hereinafter called OPTCL) has invited Tender vide e-NIT No..... Dated..... for the purpose of work under Package(s) No...../ purchase of ----- .

1. Now, therefore, in accordance with Notice Inviting Tender (e-NIT) No..... Dated of OPTCL, Ms/Shri.....Address..... Wish / wishes to participate in the said tender and as a Bank Guarantee for the sum of Rs..... [Rupees in words-----] valid for a period ofdays is required to be submitted by the bidder, as per Tender Specification, we the _____) [indicate the name, Address & Code of the bank] [hereinafter referred to as "Bank"] at the request of Ms/Shri..... [hereinafter referred to as "Bidder"] do hereby unequivocally and unconditionally guarantee and undertake to pay during the above said period on written request by the <Tender Issuing Authority, Central Procurement Cell (CPC) ODISHA POWER TRANSMISSION CORPORATION Ltd. , Bhubaneswar an amount not exceeding Rs..... to OPTCL., without any reservation. The guarantee would remain valid up to [Date] and if any further extension to this is required, the same will be extended on receiving instruction from ----- on whose behalf this Bank Guarantee has been issued.

2. We, the _____ [indicate the name of the Bank, Address, Code] do hereby further undertake to pay the amounts due and payable under this guarantee without any demur, merely on a demand from OPTCL. Any such demand made on the Bank shall be conclusive as regards the amount due and payable by the Bank under this guarantee. However, our liability under this guarantee shall be restricted to an amount not exceeding Rs..... (Rupees in words.....)

3. We undertake to pay to OPTCL any money so demanded notwithstanding any dispute or disputes so raised by the bidder in any suit or proceeding instituted/pending before any court or tribunal relating thereto, our liability under this present being absolute and unequivocal. The payment so made by us under this bond shall be a valid discharge of our liability for payment thereunder and the bidder shall have no claim against us for making such payment.
4. We, the _____ Bank further agree that the guarantee herein contained shall remain in full force and effect during the aforesaid period of _____ days [in words]..... (as per Tender Specification) and it shall continue to be so enforceable till all the dues of OPTCL under or by virtue of the said Bid have been fully paid and its claims satisfied or discharged or till OPTCL certifies that the terms and conditions of the said Bid have been fully and properly carried out by the said bidder and accordingly discharges this guarantee. Unless a demand or claim under this guarantee is made on us or our Branch Office at Bhubaneswar <Mention Name, Address & Code of the Branch Office at Bhubaneswar of Issuing Bank> in writing on or before _____ we shall be discharged from all liability under this guarantee thereafter.
5. We the _____ Bank further agree with OPTCL that OPTCL shall have the fullest liberty without our consent and without affecting in any manner our obligations hereunder to vary any of the terms and conditions of the said Bid or to extend time of performance by the said Bidder from time to time or to postpone for any time or from time to time any of the powers exercisable by OPTCL against the said Bidder and to forbear or enforce any of the terms and conditions relating to the said Bid and we shall not be relieved from our liability by reason of any such variation, postponement or extension granted to the Bidder or for any forbearance, act or omission on the part of OPTCL or any indulgence by OPTCL to the said Bidder or by any such matter or thing whatsoever which under the law relating to sureties would, but for this provision, have the effect of so relieving us.
6. This guarantee will not be discharged due to the change in the name, style and constitution of the Bank and/or of the Bidder.
7. We _____ [indicate the name of Bank, Address & Code] lastly undertake not to revoke this guarantee during its currency except with the previous consent of OPTCL in writing .
8. We, the _____ Bank (Name, Address & Code) further agree that this guarantee shall also be invocable at our place of business at ----- Branch of **Bhubaneswar**(indicate Name, Address & Code of the Branch at Bhubaneswar) in the State of Odisha.”

“ Notwithstanding anything contained herein”

- a) Our liability under the bank guarantee shall not exceed Rs.------(Rupees in words-----) only.
- b) This Bank guarantee shall be valid up to -----.

c) We or our Branch at Bhubaneswar <Mention Name, Address & Code.....> shall be liable to pay guaranteed amount or any part thereof under this guarantee only if you serve upon us at----- Branch of Bhubaneswar a written claim or demand on or before,

The Bank Guarantee is issued in ~~paper~~ e-form and Advice transmitted through SFMS with required details to the beneficiary's advising bank (ICICI Bank Bhubaneswar, IFSC Code ICIC0000061).

Dated, the _____ Day of _____

For _____ [Indicate name of Bank]

Signature

Full name

Designation

Power of Attorney No.

Date.....

Seal of the Bank.....

WITNESS: (SIGNATURE WITH NAME AND ADDRESS)

(1)

Signature

Full name

(2)

Signature

Full name

N.B.:

1. Name of the Bidder.:
2. BG No & Date :.....
3. Amount (In Rs.):.....
4. Validity up to :.....
5. E-NIT No.....
6. Package/Works No.....
7. Name, Address & Code of the Issuing Bank:.....
8. Name, Address & Code Bhubaneswar Branch of the Issuing Bank:.....

9. The Bank Guarantee shall be accepted after getting SFMS advice as per details below.

Format for SFMS details

(The Unique Identifier for field 7037 is “OPTCL541405793”)

Sl. No	PARTICULARS	TYPE	DETAILS
1	Type of Bank Guarantee	Mandatory	EMD
2	Currency & Amount	Mandatory	
3	Validity Period(from—to --)	Mandatory	
4	Effective Date	Mandatory	
5	End date of lodgment of Claim	Mandatory	
6	Place of lodgment of claim	Mandatory	Bhubaneswar, Branch Name----- of Bhubaneswar Branch code----- of Bhubaneswar Branch Address ----- at Bhubaneswar
7	Issuing Branch IFSC Code	Mandatory	
8	Issuing Branch name & address	Mandatory	
9	Name of applicant and its details	Mandatory	
10	Name of Beneficiary and its details	Mandatory	
11	Beneficiary's Bank/Branch and IFSC Code	Mandatory	ICICI Bank Ltd IFSC Code-ICIC0000061
12	Beneficiary's Bank/Branch name and address	Mandatory	ICICI Bank Ltd Bhubaneswar Main Branch, Bhubaneswar
13	Sender to receiver information	Mandatory	
14	Purpose of Guarantee	Mandatory	EMD
15	Reference/Description of the underlined tender/contract	Mandatory	NIT No

N.B. : To be Stamped in accordance with Stamp Act and the Non-Judicial Stamp Paper of appropriate value should be in the name of Issuing Bank.

ANNEXURE-VII

**PROFORMA FOR COMPOSITE BANK GUARANTEE FOR SECURITY DEPOSIT,
PAYMENT AND PERFORMANCE**

~~(To be stamped in accordance with Stamp Act and the Non-Judicial stamp paper of appropriate value should be in the name of the Issuing Bank.)~~

Ref No:-
e-Bank Guarantee No.
Date:

e-BG Amount:.....

Validity Period:.....

This Guarantee Bond is executed this..... day of by us the..... Bank at , P.O..... , Dist....., State..... and Code No.....

Whereas the ODISHA POWER TRANSMISSION CORPORATION Limited, Janpath, Bhubaneswar, a company constituted under the Companies Act-1956 (hereinafter called OPTCL) has issued Letter of Award (LOA) No..... Dated..... for the purpose of work under Package No..... (herein after called "the Agreement") to M/s/Shri , Address..... (herein after called the "Contractor") for supply, erection, installation & commissioning and associated civil works under the above LoA and whereas OPTCL has agreed (1) to exempt demand of security deposit under the terms and conditions of the LOA (2) to release payment of the cost of the Contract Price to the Contractor on furnishing by the Contractor to OPTCL a Contract Performance Bank Guarantee (CPBG) of the value of 10% ~~3%~~ of the Contract Price of the said Agreement.

1. Now therefore, in accordance with the terms and conditions of LOA No. _____ dated _____ for the due fulfillment by the said Contractor of the terms and conditions contained in the said agreement, on production of a Bank Guarantee for Rs. _____ (Rupees _____) only, we the bank _____ [Indicate bank Name , Address & Code] (hereinafter referred to as "the Bank") at the request of M/s/Shri _____ contractor do hereby undertake to pay to OPTCL, an amount not exceeding Rs. _____ (Rupees _____) only .

3. We, the _____ Bank [indicate the name of the Bank, Address & Code] do hereby undertake to pay the amounts due and payable under this guarantee without any demur, merely on a demand from OPTCL. Any such demand made on the bank shall be conclusive as regards the amount due and payable by the bank under this guarantee. However, our liability under this guarantee shall be restricted to an amount not exceeding Rs. _____ (Rupees----- In Words).

3. We, the Bank also undertake to pay to OPTCL any money so demanded not withstanding any dispute or disputes raised by the Contractor in any suit or proceeding instituted / pending before any court or tribunal relating thereto, our liability under this present being absolute and irrevocable. The payment so made by us under this bond shall be a valid discharge of our liability for payment thereunder and the Contractor shall have no claim against us for making such payment.

4. We, the _____ Bank further agree that the guarantee herein contained shall remain in full force and effect during the aforesaid period of _____ days and it shall continue to be so enforceable till all the dues of OPTCL under or by virtue of the said Agreement have been fully paid and its claims satisfied or discharged or till OPTCL certifies that the terms and conditions of the said Agreement have been fully and properly carried out by the said contractor and accordingly discharges this guarantee.

Unless a demand or claim under this guarantee is made on us or our Branch Office at Bhubaneswar <Mention Name, Address & Code of the Branch Office at Bhubaneswar of issuing Bank> in writing on or before (Date), we shall be discharged from all liability under this guarantee thereafter.

5. We, the _____ Bank [indicate the name of the Bank, Address & Code] further agree with the Board that OPTCL shall have the fullest liberty without our consent and without affecting in any manner our obligations hereunder to vary any of the terms and conditions of the said Bid or to extend time or performance by the said contractor(s) from time to time or to postpone for any time or from time to time any of the powers exercisable by OPTCL against the said contractor(s) and to forbear or enforce any of the terms and conditions relating to the said Bid and we shall not be relieved from our liability by reason of any such variation postponement or extension being granted to the said contractor(s) or for any forbearance, act or omission on the part of OPTCL or any indulgence by OPTCL to the said contractor(s) or by any such matter or thing whatsoever which under the law relating to sureties would, but for this provision, have the effect of so relieving us.

6. This guarantee will not be discharged due to the change in the name, style or constitution of the Bank and/or of the contractor(s).

7. We, the _____ Bank [indicate the name of the bank, Address & Code] lastly undertake not to revoke this guarantee during its currency except with the previous consent of OPTCL in writing.

8. We, the _____ Bank (Name, Address & Code) further agree that this guarantee shall also be invocable at our place of business at - -----Branch of **Bhubaneswar** (indicate Name, Address & Code of the Branch at Bhubaneswar) in the State of Odisha.

“ Notwithstanding anything contained herein”

a) Our liability under the bank guarantee shall not exceed Rs.----- (Rupees in words-----) only.

b) This Bank guarantee shall be valid up to -----.

c) We or our Branch at **Bhubaneswar** <Mention Name, Address & Code.....> shall be liable to pay guaranteed amount or any part thereof under this guarantee only if you serve upon us at----- Branch of Bhubaneswar a written claim or demand on or before

The Bank Guarantee is issued in ~~paper~~ e-form and Advice transmitted through SFMS with required details to the beneficiary's advising bank (**ICICI Bank Bhubaneswar**, IFSC Code ICIC0000061).

Dated, the _____ Day of _____

For _____ [Indicate name of Bank]

Signature.....

Full Name.....

Designation.....

Power Of Attorney.....

Dated.....

Seal of the Bank.....

WITNESS: (SIGNATURE WITH NAME AND ADDRESS)

1. Signature.....

Full Name.....

2. Signature.....

Full Name.....

N.B.:

1. Name of the Contractor.:

2. BG No & Date :.....

3. Amount (In Rs.):.....

4. Validity up to :.....

5. LOA No.....

6. Package No.....

7. Name, Address & Code of Issuing Bank:.....

8. Name, Address & Code of Bhubaneswar Branch of the Issuing Bank:.....

1. The Bank Guarantee shall be accepted after getting SFMS advice as per details below.

Format for SFMS details

(The Unique Identifier for field 7037 is “OPTCL541405793”)

Sl. No	PARTICULARS	TYPE	DETAILS
1	Type of Bank Guarantee	Mandatory	Contract Performance
2	Currency & Amount	Mandatory	
3	Validity Period(from—to --)	Mandatory	
4	Effective Date	Mandatory	
5	End date of lodgment of Claim	Mandatory	
6	Place of lodgment of claim	Mandatory	Bhubaneswar, Branch Name----- of Bhubaneswar Branch code----- of Bhubaneswar Branch Address ----- at Bhubaneswar
7	Issuing Branch IFSC Code	Mandatory	
8	Issuing Branch name & address	Mandatory	
9	Name of applicant and its details	Mandatory	
10	Name of Beneficiary and its details	Mandatory	
11	Beneficiary's Bank/Branch and IFSC Code	Mandatory	ICICI Bank Ltd IFSC Code-ICIC0000061
12	Beneficiary's Bank/Branch name and address	Mandatory	ICICI Bank Ltd Bhubaneswar Main Branch, Bhubaneswar
13	Sender to receiver information	Mandatory	
14	Purpose of Guarantee	Mandatory	Contract Performance
15	Reference/Description of the underlined tender/contract	Mandatory	LOA No----

N.B. : To be Stamped in accordance with Stamp Act and the Non-Judicial Stamp Paper of appropriate value should be in the name of Issuing Bank

ANNEXURE- VIII

CHART SHOWING PARTICULARS OF EARNEST MONEY DEPOSIT FURNISHABLE BY TENDERERS

1.	Central and State Government Undertakings	Exempted
2.	All other inside & outside state units.	The amount of EMD as specified in the specification /Tender Notice in shape of bank guarantee /DD.

NB: - REFUND OF E.M.D.

- [a] In case of unsuccessful tenderers, the EMD will be refunded immediately after the tender is decided. In case of successful tenderer, this will be refunded only after furnishing of Composite Bank Guarantee referred to in clause No.19 of Section-II of this specification.

Suits, if any, arising out of EMD shall be filed in a court of law to which the jurisdiction of High Court of ODISHA extends.

- [b] Earnest Money will be forfeited if the tenderer fails to accept the letter of intent/purchase order, issued in his favour or revises the bid price[s] within the validity period of Bid.

N.B:- The annexure is to be filled up & uploaded as PDF

ANNEXURE-IX

DATA ON EXPERIENCE

Sl. No	PARTICULARS	
[a]	Name of the manufacturer:	
[b]	Standing of the firm as manufacturer of equipment quoted	
[c]	Description of equipment similar to that quoted [supplied and installed during the last two years with the name(s) of the Organisations to whom supplies were made]	
[d]	Details as to where installed etc.	
[e]	Testing facilities at manufacturer's works	
[f]	If the manufacturer is having collaboration with another firm, details regarding the same & present status	
[g]	A list of purchase orders, executed during last three years	
[h]	A list of similar equipments of specified KVA rating, voltage class, Impulse level, short circuit rating, designed, manufactured, tested & commissioned which are in successful operation for at least two years from the date of commissioning with legible users certificate. Users full complete postal address / fax / phone must be indicated (Refer Clause No. 7 of the part – I, section –II of the specification.	

Place:

Date:

Signature of tenderer
Name, Designation, Seal

N.B:- The annexure is to be filled up & uploaded as PDF

ANNEXURE-X

**SCHEDULE OF SPARE PARTS FOR FIVE YEARS OF NORMAL
OPERATION & MAINTENANCE**

SL No.	Particulars	Quantity	Unit delivery rate	Total price

Place:

Date:

Signature of Tenderer
Name, Designation, Seal

N.B:- The annexure is to be filled up & uploaded as PDF

ANNEXURE-XI

SCHEDULE OF INSTALLATIONS

Rated MVA	Rated Voltage	Place of Installation & complete postal address	Year of commissioning

Place:

Date:

Signature of Tenderer
Name, Designation, Seal

N.B:- The annexure is to be filled up & uploaded as PDF

ANNEXURE-XII(A)

SCHEDULE OF DEVIATION (TECHNICAL).

Tenderer shall enter below particulars of his alternative proposal for deviation from the specification, if any.

Technical deviations.

(To be filled up by the tenderer as indicated in the excel sheet)

ANNEXURE-XII(B)

SCHEDULE OF DEVIATION (COMMERCIAL).

Commercial deviations.

(To be filled up by the tenderer as indicated in the excel sheet)

ANNEXURE – XIII

LITIGATION/ARBITRATION HISTORY

Year.	Award for or against bidder	Name of client, cause of litigation and matter in dispute	Disputed amount (current value in Rs.)

Place: -

Date

Signature of Tenderer:
Name, Designation, Seal

ANNEXURE – XIV

AFFIDAVIT OF BIDDER

BEFORE Sri / _____
Notary at. _____

AFFIDAVIT

WHEREAS the Odisha Power Transmission Corporation Ltd., Bhubaneswar (OPTCL) has floated its Tender No _____ inviting bids from eligible bidder to execute the work of _____.

And WHEREAS M/s. _____ (briefly "Bidder") has offered its bid on _____ in response to the said Tender No. _____ of the OPTCL expressing its interest to execute the work as specified therein.

AND WHEREAS the said Tender No. _____ of OPTCL requires the Bidder to solemnly affirm the correctness of the document and information furnished in its bid, so offered to OPTCL.

NOW TEREFORE, in response to the requirement, the Tender No. _____ of OPTCL and having been duly authorized by the Bidder, I Sri/ Mrs. _____ aged about _____ years. Son / Daughter / Wife of Sri / Mrs. _____. At present working as _____ of M/s. _____ (the Bidder) do hereby solemnly affirm and state as follows.

1. That I am competent and have been duly authorized by the Bidder M/s. _____ to swear this affidavit on its behalf.
2. That the documents and information furnished by the Bidder in its bid offered in respect to the said Tender No. _____ of OPTCL are true and correct.
3. That in the event any document and information as furnished by the bidder in response to the said Tender No. _____ of OPTCL at any time as to be not correct / wrong, the OPTCL shall be competent and at liberty without any show cause to the Bidder to terminate its contact/ agreement with the bidder if any.
4. The OPTCL shall also be competent, without any reference to the Bidder, to blacklist the Bidder and debar the Bidder from participating in any other Tender of OPTCL pursuant to its consideration / finding that the Bidder has furnished any incorrect / wrong document and information tendered / made pursuant to Tender No. _____ of OPTCL.
5. That the affirmation made herein above is / are correct and true and nothing stated herein is false.

Identified by

DEPONENT ADVOCATE

ANNEXURE – XV

FORMAT FOR EXTENSION OF BANK GUARANTEE

(To be stamped in accordance with Stamp Act and the Non-Judicial stamp paper should be in the name of the issuing Bank)

Ref No:- **Date:-**

Sub: Extension of Bank Guarantee No.**for Rs.**
..... **favouring yourselves, expiring on****on**
account of **M/s.** **in respect of**
LOA No. **dated** **(hereinafter called**
original Bank Guarantee).

At the request of M/s., we..... Bank,
branch office atand having its Head Office at
do hereby extend our liability under the above mentioned Guarantee No.
..... Datedfor a further period ofyears
/ months/ days from to expire on,except as
provided above, all other terms and conditions of the original Bank Guarantee No.
..... dated shall remain unaltered and binding.

Please treat this as an integral part of the original Bank Guarantee to which it would
be attached.

“ Notwithstanding anything contained herein”

a) Our liability under the bank guarantee shall not exceed Rs.------(Rupees in
words-----) only.

b) This Bank guarantee shall be valid up to -----.

c) We or our Branch at **Bhubaneswar** <Mention Name, Address & Code.....>
shall be liable to pay guaranteed amount or any part thereof under this guarantee
only if you serve upon us at----- Branch of Bhubaneswar a written claim or demand
on or before,

The Bank Guarantee extension is issued in paper form and Advice transmitted
through SFMS with required details to the beneficiary's advising SB A/C No.
**028401004346 (ICICI Bank Ltd., N5/535 IRC Village, Nayapalli ,Bhubaneswar-
12,IFSC code-ICIC0000284).**

Dated this Day of20..... at

For[Indicate name of the Bank]

Signature.....

Full Name

Designation

Power Of Attorney No.....

Seal of the Bank.....

NOTE : i) SFMS advice as per details below.

Format for SFMS details

Sl. No	PARTICULARS	TYPE	DETAILS
1	Type of Bank Guarantee	Mandatory	Contract Performance/
2	Currency & Amount	Mandatory	
3	Validity Period(from—to --)	Mandatory	
4	Effective Date	Mandatory	
5	End date of lodgment of Claim	Mandatory	
6	Place of lodgment of claim	Mandatory	Bhubaneswar, Branch Name----- of Bhubaneswar Branch code----- of Bhubaneswar Branch Address ----- at Bhubaneswar
7	Issuing Branch IFSC Code	Mandatory	
8	Issuing Branch name & address	Mandatory	
9	Name of applicant and its details	Mandatory	
10	Name of Beneficiary and its details	Mandatory	
11	Beneficiary's Bank/Branch and IFSC Code	Mandatory	ICICI Bank Ltd IFSC Code-ICIC0000061
12	Beneficiary's Bank/Branch name and address	Mandatory	ICICI Bank Ltd Bhubaneswar Main Branch, Bhubaneswar
13	Sender to receiver information	Mandatory	
14	Purpose of Guarantee	Mandatory	Contract Performance/
15	Reference/Description of the	Mandatory	NIT No/LoA No

ANNEXURE – XVI

Tender specific authorization from the manufacturer of the offered equipment.

**FORM OF MANUFACTURER’S AUTHORIZATION
(To be submitted along with the Techno-Commercial Bid)
(Manufacturer’s Authorization Form for DPC)
(On Manufacturer’s Letter-head)**

To: [Insert: name of Employer]

Dear Sir,

WE [insert: name of Manufacturer] who are established and reputable manufacturers of [insert: name and/or description of the plant & equipment] having production facilities at [insert: address of factory] do hereby authorize [insert: name & address of Bidder] (hereinafter, the “Bidder”) to submit a bid, and subsequently negotiate and sign the Contract with you against IFB [insert: title and reference number of Invitation for Bids] including the above plant & equipment or other goods produced by us.

We hereby extend our full guarantee and warranty for the above specified plant & equipment materials or other goods offered supporting the supply, installation and achieving of Operational Acceptance of the plant by the Bidder against these Bidding Documents, and duly authorize said Bidder to act on our behalf in fulfilling these guarantee and warranty obligations. We also hereby declare that we and, [insert: name of the Bidder] have entered into a formal relationship in which, during the duration of the Contract (including warranty / defects liability) we, the Manufacturer or Producer, will make our technical and engineering staff fully available to the technical and engineering staff of the successful Bidder to assist that Bidder, on a reasonable and best effort basis, in the performance of all its obligations to the Purchaser under the Contract.

For and on behalf of the Manufacturer

Signed: _____

Date: _____

In the capacity of [insert: title of position or other appropriate designation] and this should be signed by a person having the power of attorney to legal bind the manufacturer.

Date:.....

Place:.....

(Signature).....

(Printed Name).....

(Designation).....

(Common Seal).....

Note 1. The letter of Authorisation should be on the letterhead of the Manufacturer and should be signed by a person competent and having Power of Attorney to legally bind the Manufacturer. It shall be included by the bidder in its bid.

2. Above undertaking shall be registered or notarized so as to be legally enforceable.

ANNEXURE-XVII

DPIIT Certificate (to be furnished in bidder company's letter head)

I have read the clause regarding restrictions on procurement from a bidder of a country which shares a land border with India and on sub-contracting to contractors from such countries; I certify that this bidder is not from such a country or, if from such a country, has been registered with the Competent Authority and will not sub-contract any work to a contractor from such countries unless such contractor is registered with the Competent Authority. I hereby certify that this bidder fulfils all requirements in this regard and is eligible to be considered. [Where applicable evidence of valid registration by the Competent Authority shall be attached.]

Authorized signatory

Company seal

Section IV

Technical Specification for ADSS Accessories

**TENDER SPECIFICATION NO.
EIC-BharatNet-e-Tender-2/2026-27**

Volume-I

Description **.....Page**

Technical Specification ADSS Accessories.

Technical Specification of ADSS Accessories(Type- I Helix).

1. TYPES OF ACCESSORIES AND FIXTURES:

Type -I Helix Type(Heavy duty),which are to be used for installation of 96F/48F/24F ADSS Type III A.

1.1 FORMED OFC DEAD END AND TERMINATION FITTINGS:

These fittings are used at tension/termination poles (dead end poles), or poles where splices are located and the poles where the overhead alignment takes a turn, (angle exceeding more than 15 degrees) as shown in below fig. 1.

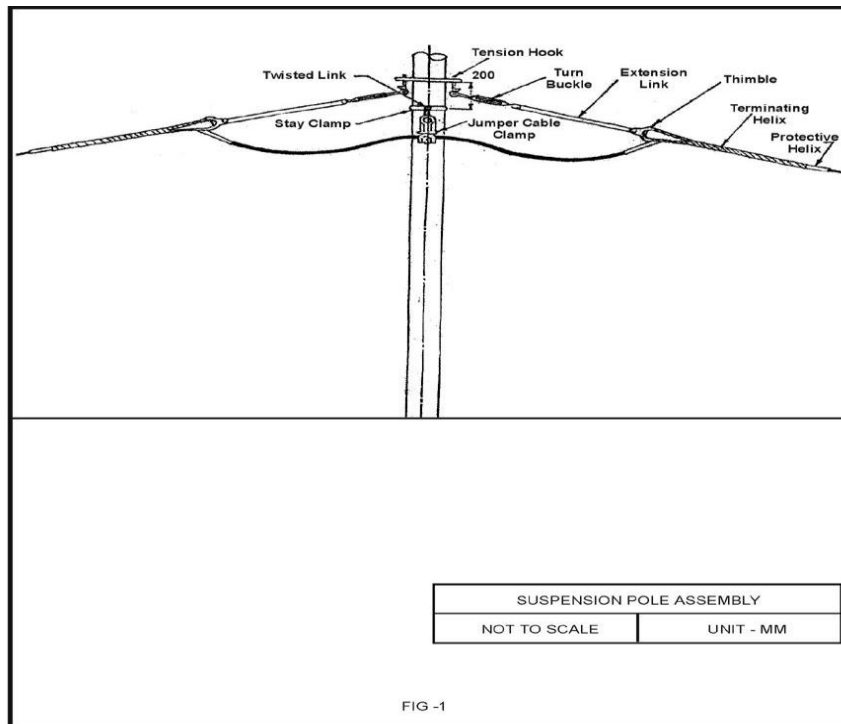

1.2 J-SHAPED TENSION HOOK:

J - Shaped tension hook is for the installation on cross arm channel C (C-Bracket) of the poles as shown in fig.

6.

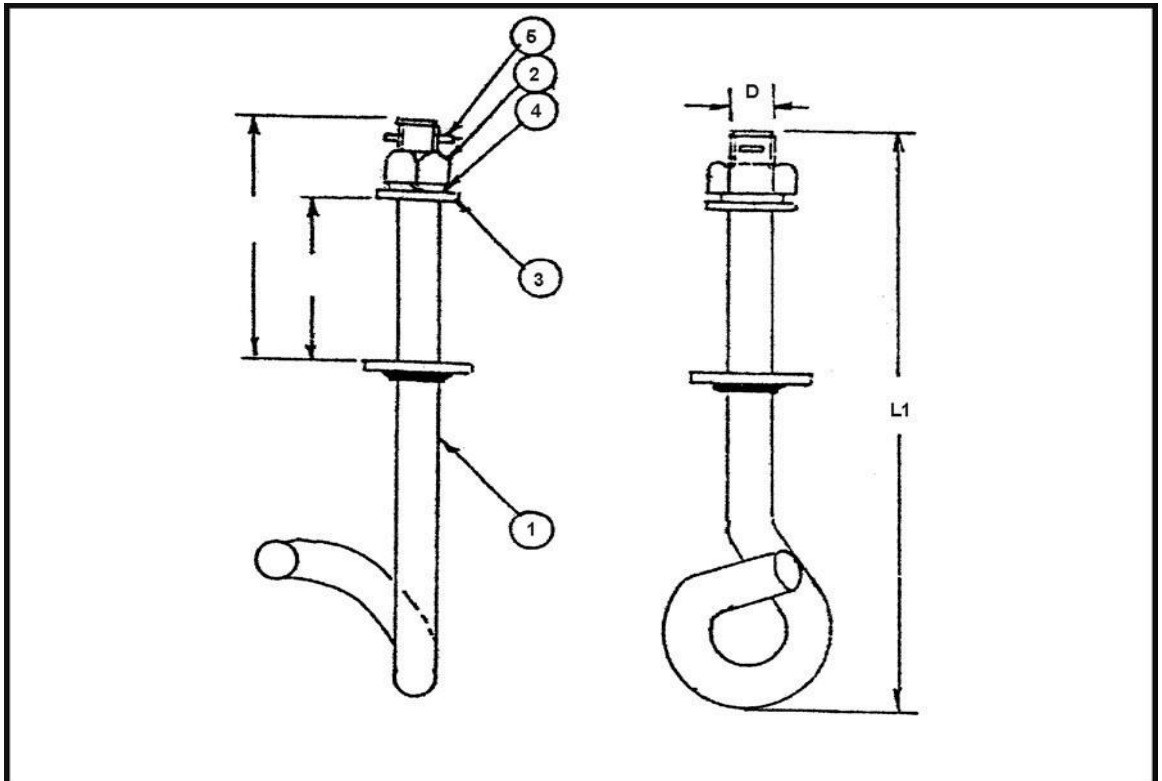

DIMENSIONS IN MM :

L1	L2	L3	D
177	75	50	12

NOTE :- TOLERANCE SHALL BE AS PER IS : 2102
 (DETAIL AS PER GR, UNLESS UNTILL SPECIFIED)
 TO BE USED HERE C-BRACKET IS AVAILABLE ON POLE FOR FITMENT OF TENSION HOOK
 HOT DIP GAVANISED AS PER IS : 2629

DESCRIPTION	METERIAL	REF. Spec.	Qty.
1 BODY	ALLOY STEEL GALVANISED	IS : 2004	1
2 NUT	MILD STEEL GALVANISED	IS : 1363	1
3 PLAIN WASHER	MILD STEEL GALVANISED	IS : 2016	1
4 SPRING WASHER	SPRING STEEL GALVANISED	IS : 3063	1
5 SPILT PIN	STAINLESS STEEL	IS : 549	1

TENSION HOOK	
NOT TO SCALE	UNIT - MM

FIG - 6

1.3 TURN BUCKLE:

Galvanized forged steel turn - buckle is used at the dead end and at tension positions (for adjusting the sag & tension) as shown in fig. 7.

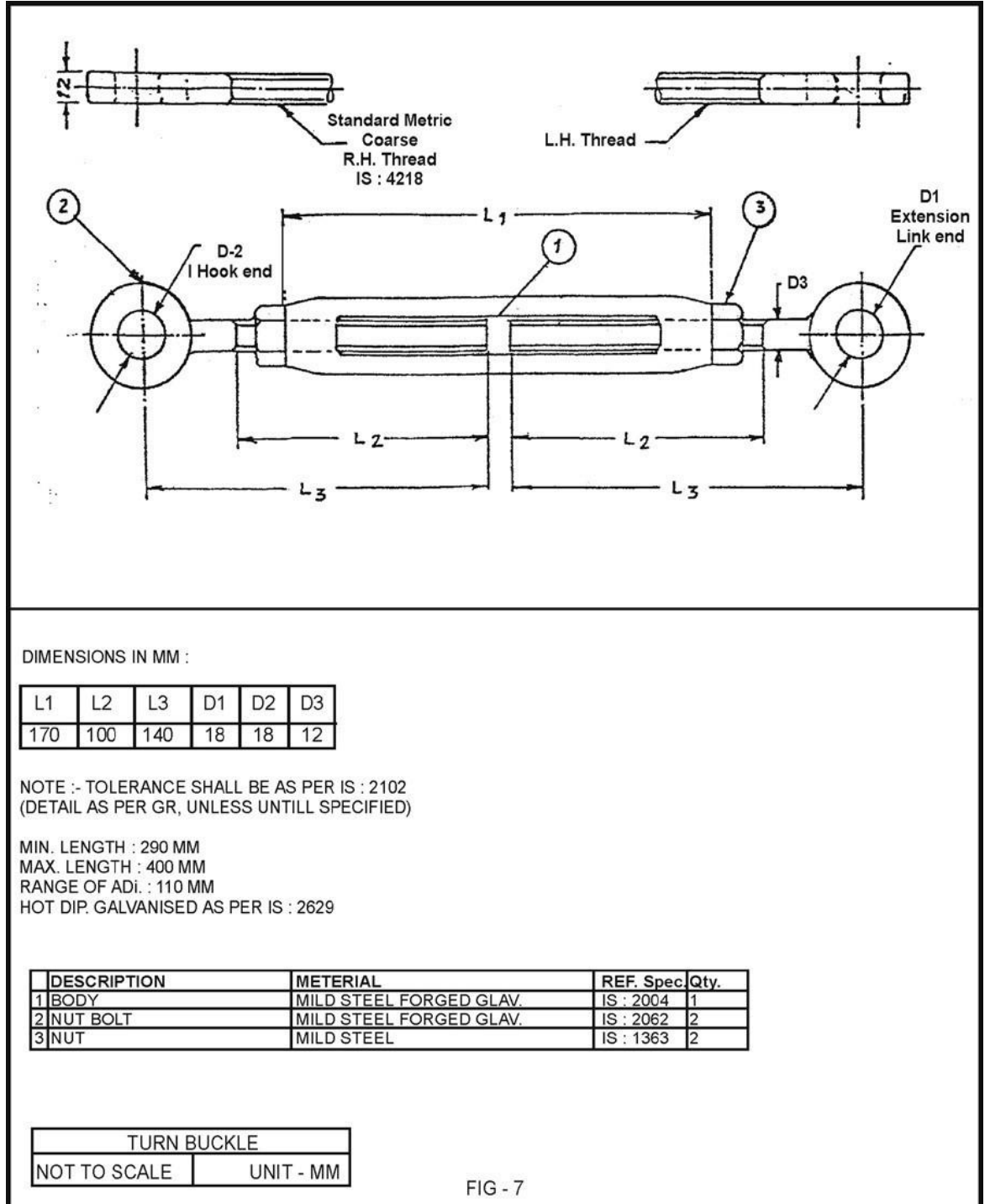

1.4 EXTENSION LINK:

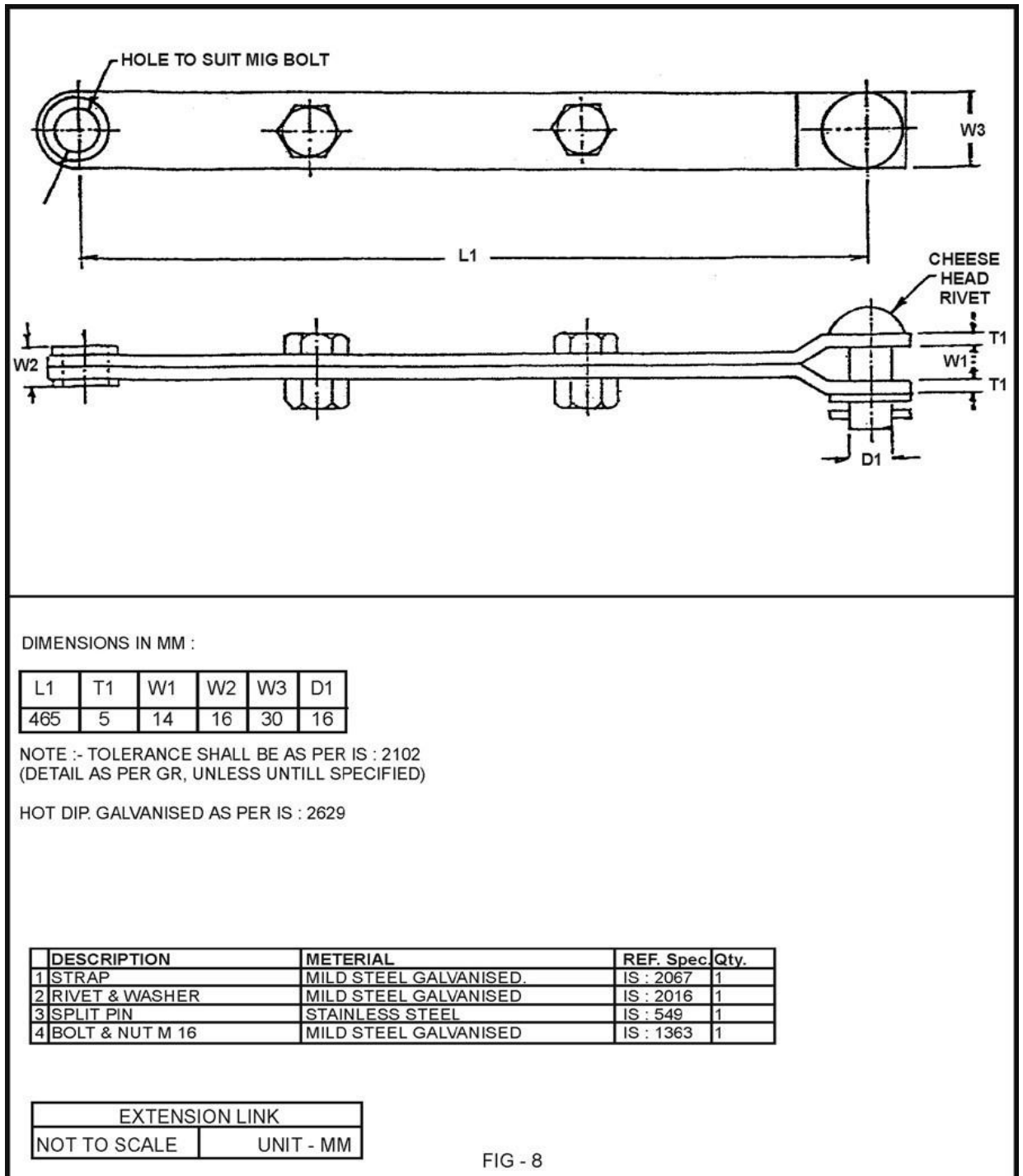

Galvanized steel extension link is used along with turn buckle as shown in fig. 8.

1.5 CLEVIS THIMBLE:

Aluminium alloy die cast thimble is used to attach the extension link and for accommodating the loop of the helically formed terminating helix at the other and its smooth internal contour as shown in fig.9.

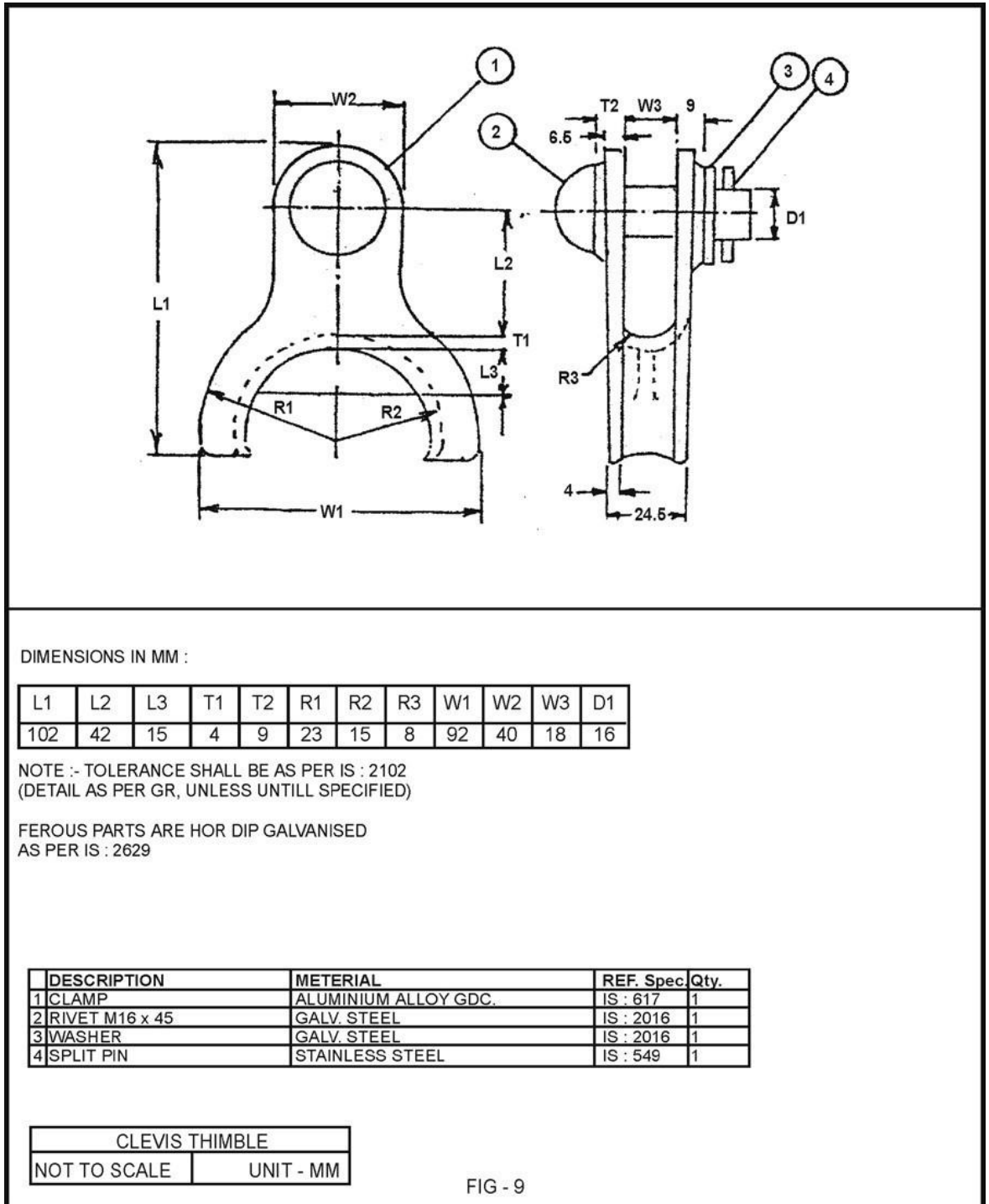

1.6 PROTECTIVE HELIX (T):

Set of aluminium alloy helically formed protective helix having predetermined spiral shape is used & making them conveniently applied on the optical Fiber cable without excessive clamping pressure at any point. See fig.

11.

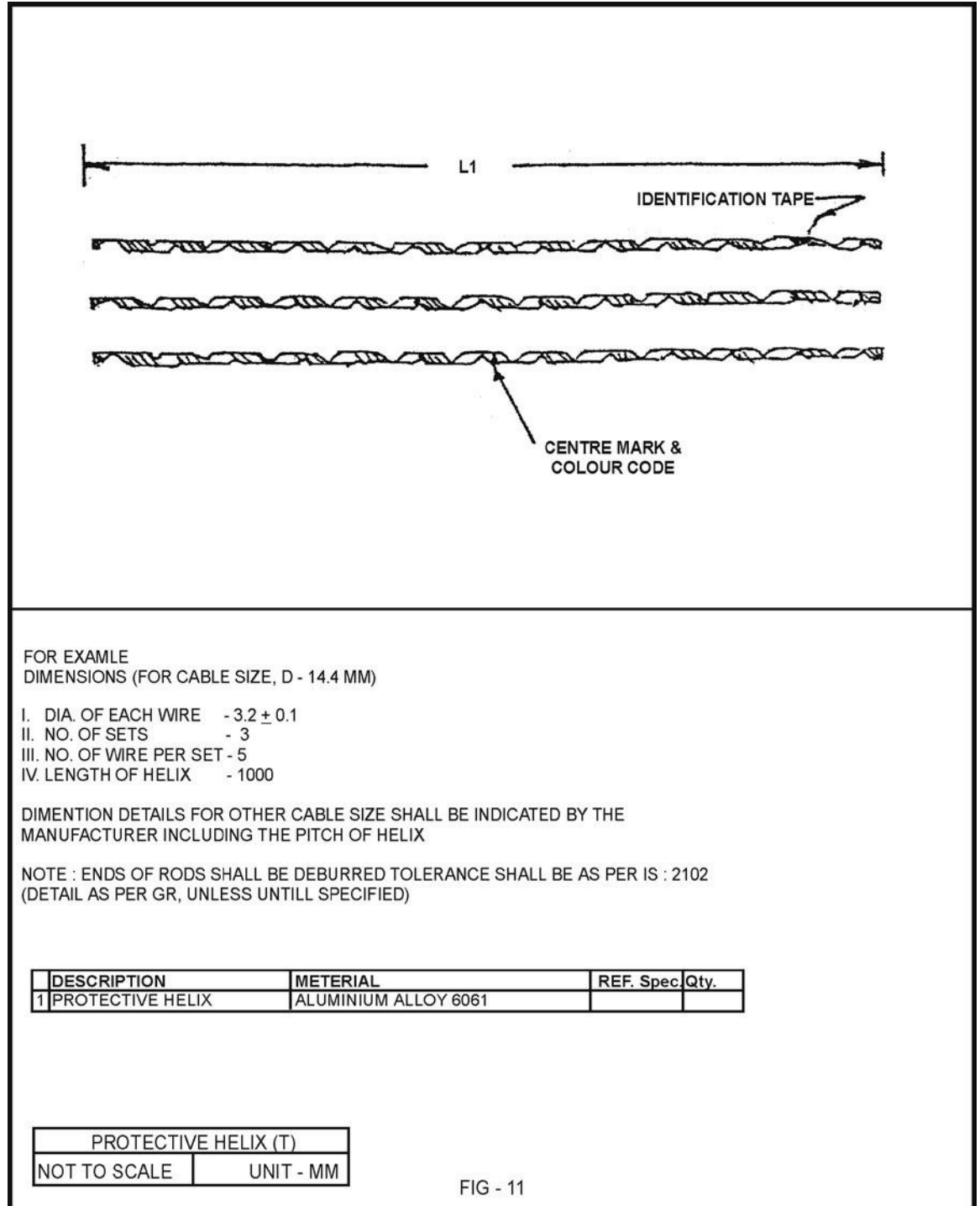

1.7 TERMINATING HELIX:

Helically formed terminating helix of Aluminized steel having a prefabricated loop shall be to fit into the grooved contour of the thimble and for fixing over protective helix over the optical Fiber cable. See fig.12.

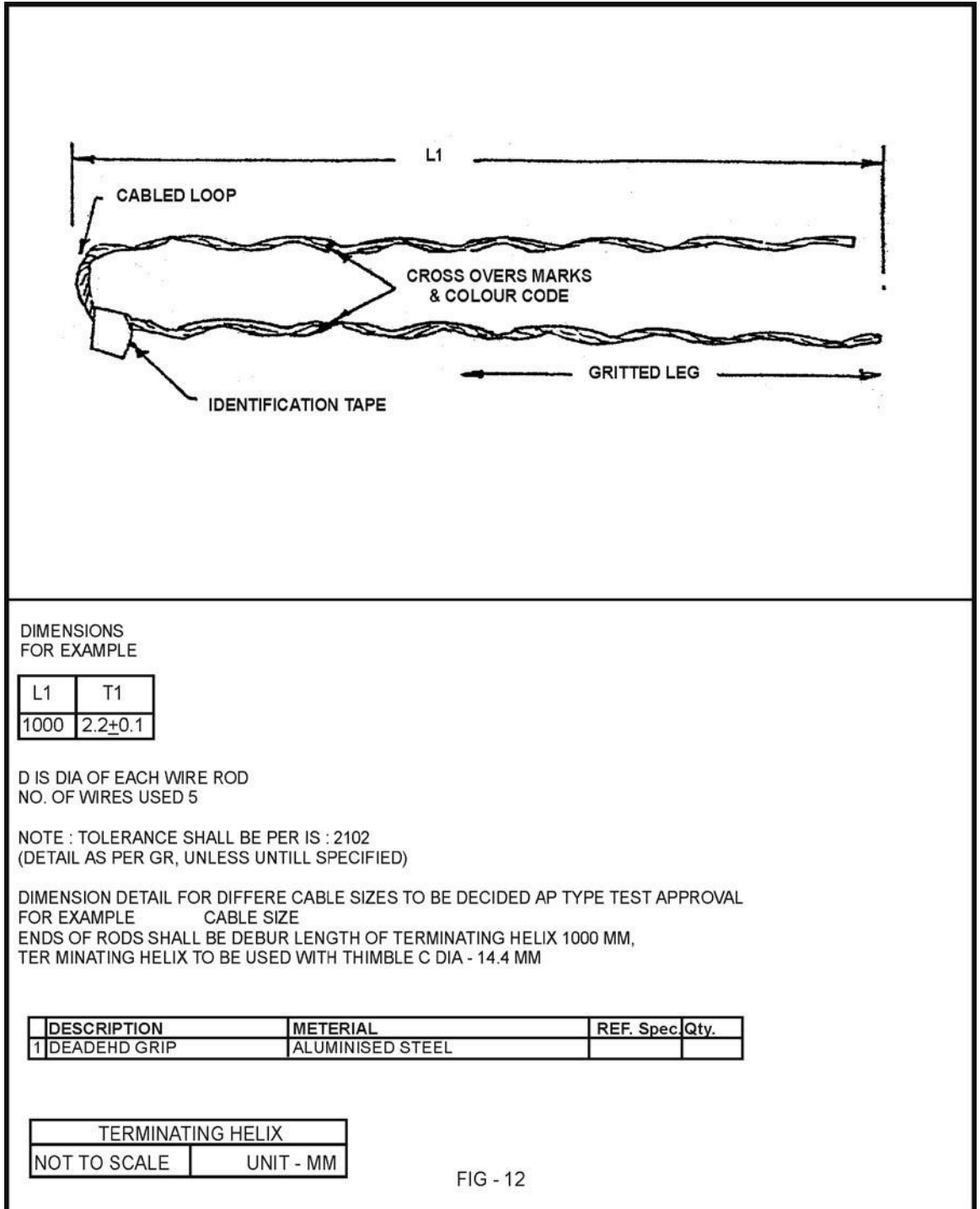

1.8 JUMPER CABLE CLAMP:

Galvanized steel jumper cable clamp is used to support the through length of optical Fiber cable at the intermediate tension poles as shown in fig. 15.

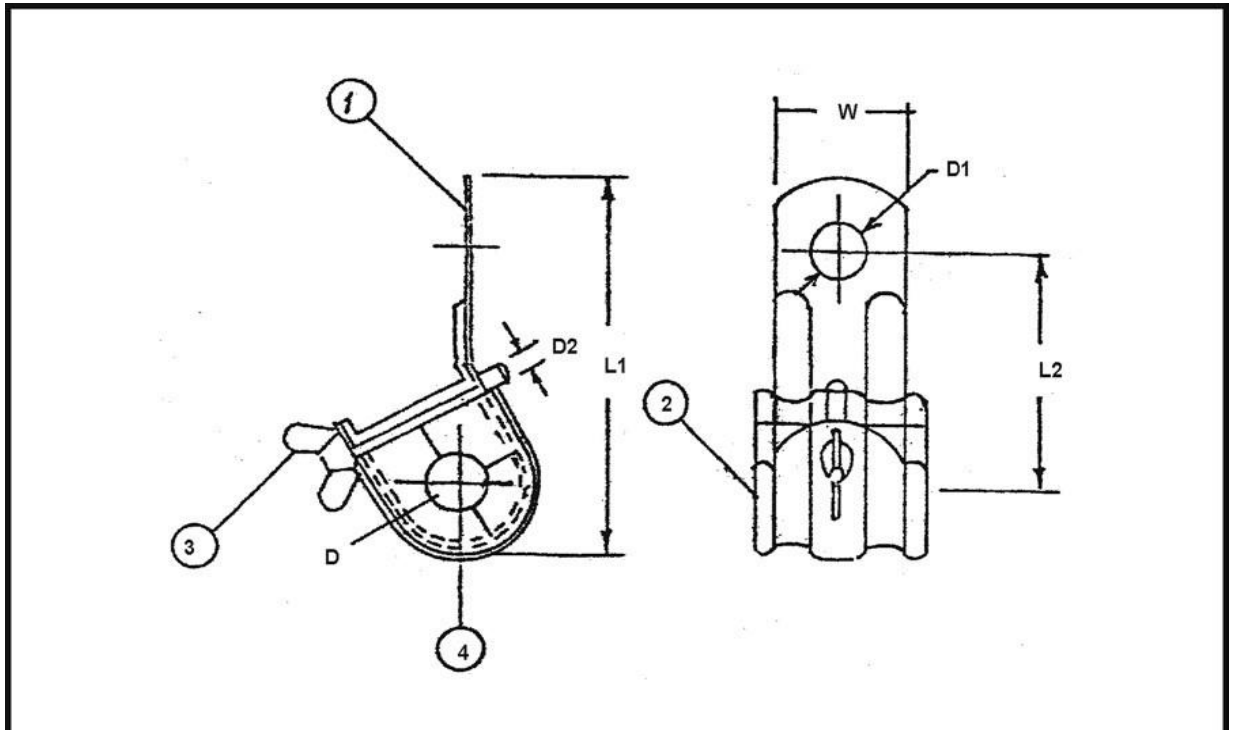

DIMENSIONS IN MM

L1	L2	D1	D2	W
105	65	17.5	5-6	35

DIMENSIONS IN MM OF INSERT PAD

L	INNER DIA	OUTER DIA
40	15	30

NOTE : TOLERANCE SHALL BE AS PER IS : 2102
 (DETAIL AS PER GR, UNLESS UNTILL SPECIFIED)
 INSERT IN TOW HALVES D TO SUIT CABLE DIA FERROUS PARTS ARE HOT DIP GALVASIED AS PER IS : 2629

DESCRIPTION	METERIAL	REF. Spec.	Qty.
1 STRAP	MILD STEEL GALY	IS : 2062	1
2 INSERT	POLYCHLORADPRENE COMPOUNDE		1
3 WING BOLT	MILD STEEL GALY	IS 2062	1

JUMPER CABLE CLAMP	
NOT TO SCALE	UNIT - MM

FIG - 15

1.9 TWISTED EYE LINK:

The twisted eye link is used for installing suspension fitting on stay clamp or on tension hook as shown in fig. 14.

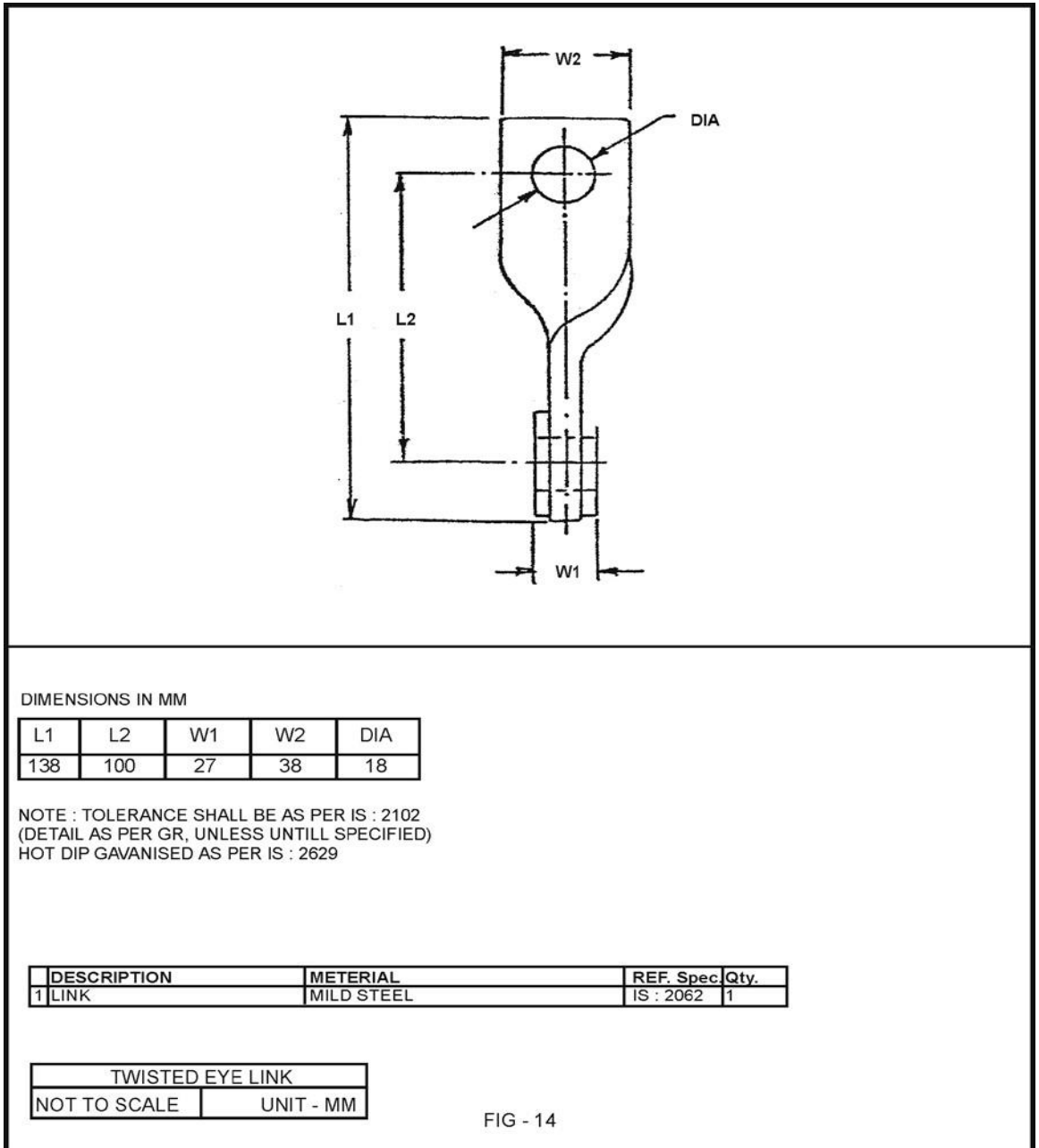

1.10 PROTECTIVE HELIX (S)

Set of aluminium alloy helically formed protective helix having predetermined spiral shape is used & making them conveniently applied on the optical Fiber cable without excessive clamping pressure at any point. See fig.

10.

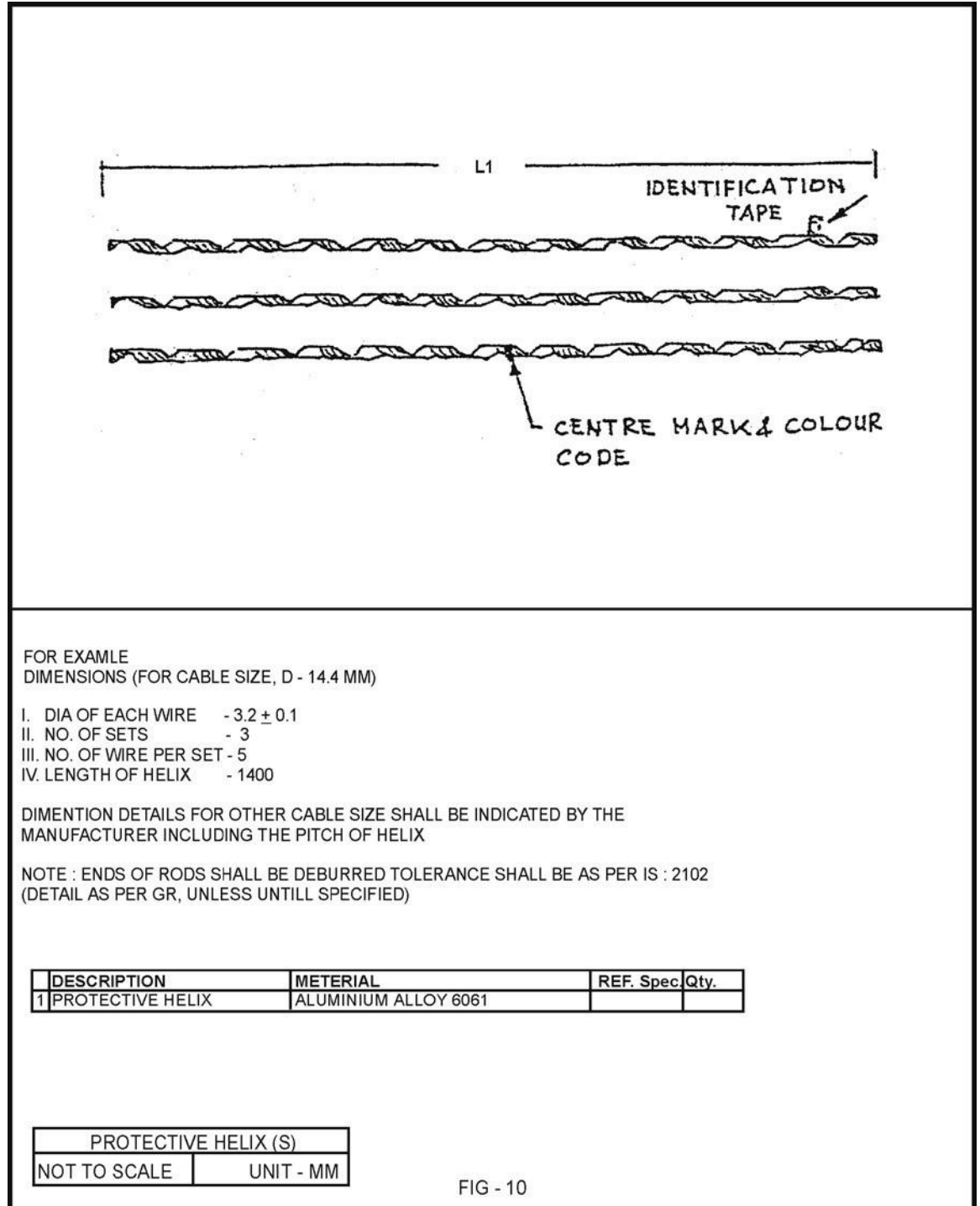

1.11 ARMOUR GRIP HELIX:

Set of aluminum alloy armour grip helix is used for fixing on the profile shaped elastomer pad for proper strut action, grip & bird caging as shown in fig. 3.

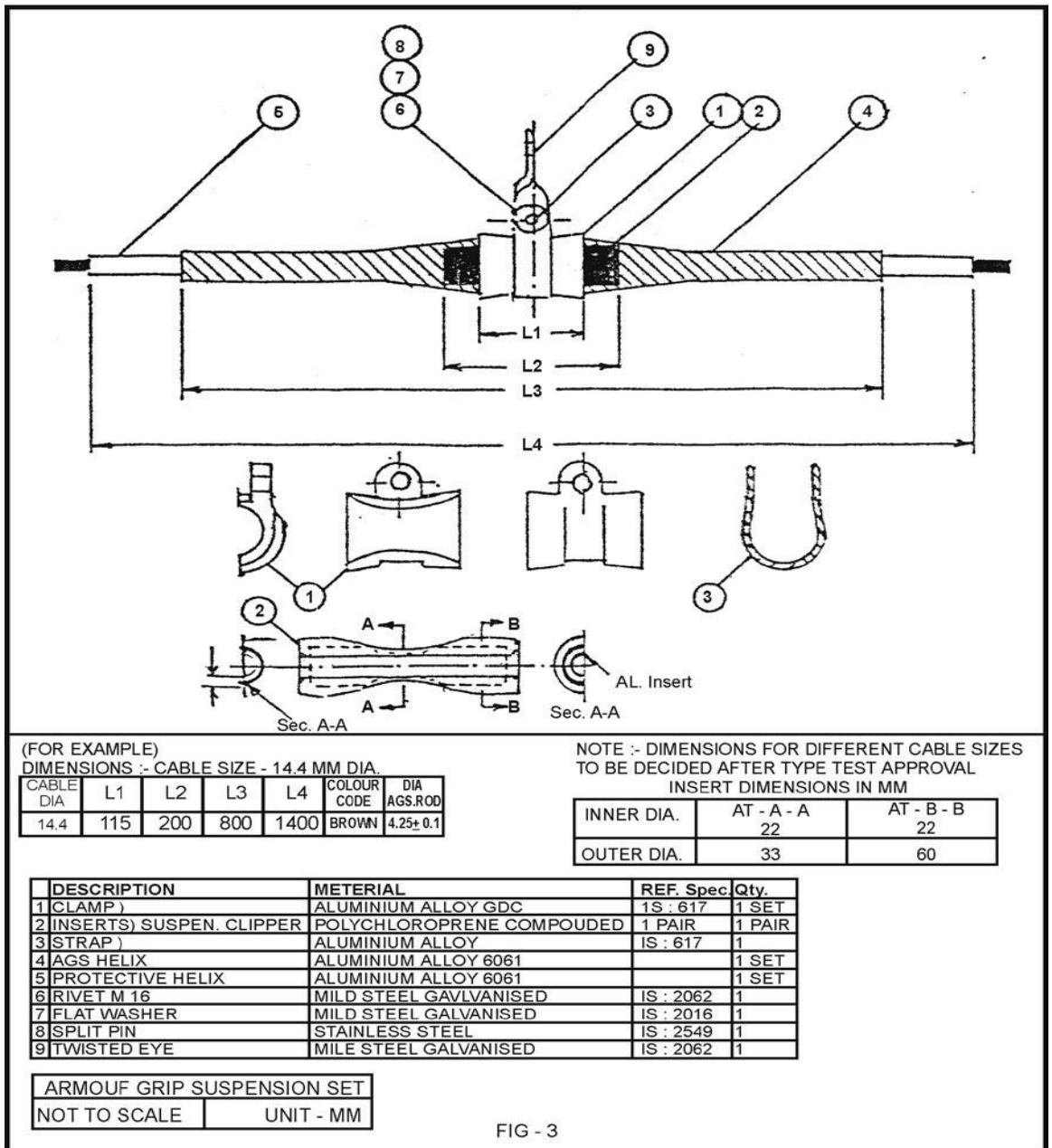

1.12 SPIRAL VIBRATION DAMPER (SVD)

Helically formed spiral vibration dampers are used on both sides of suspension fittings as shown in fig. 13.

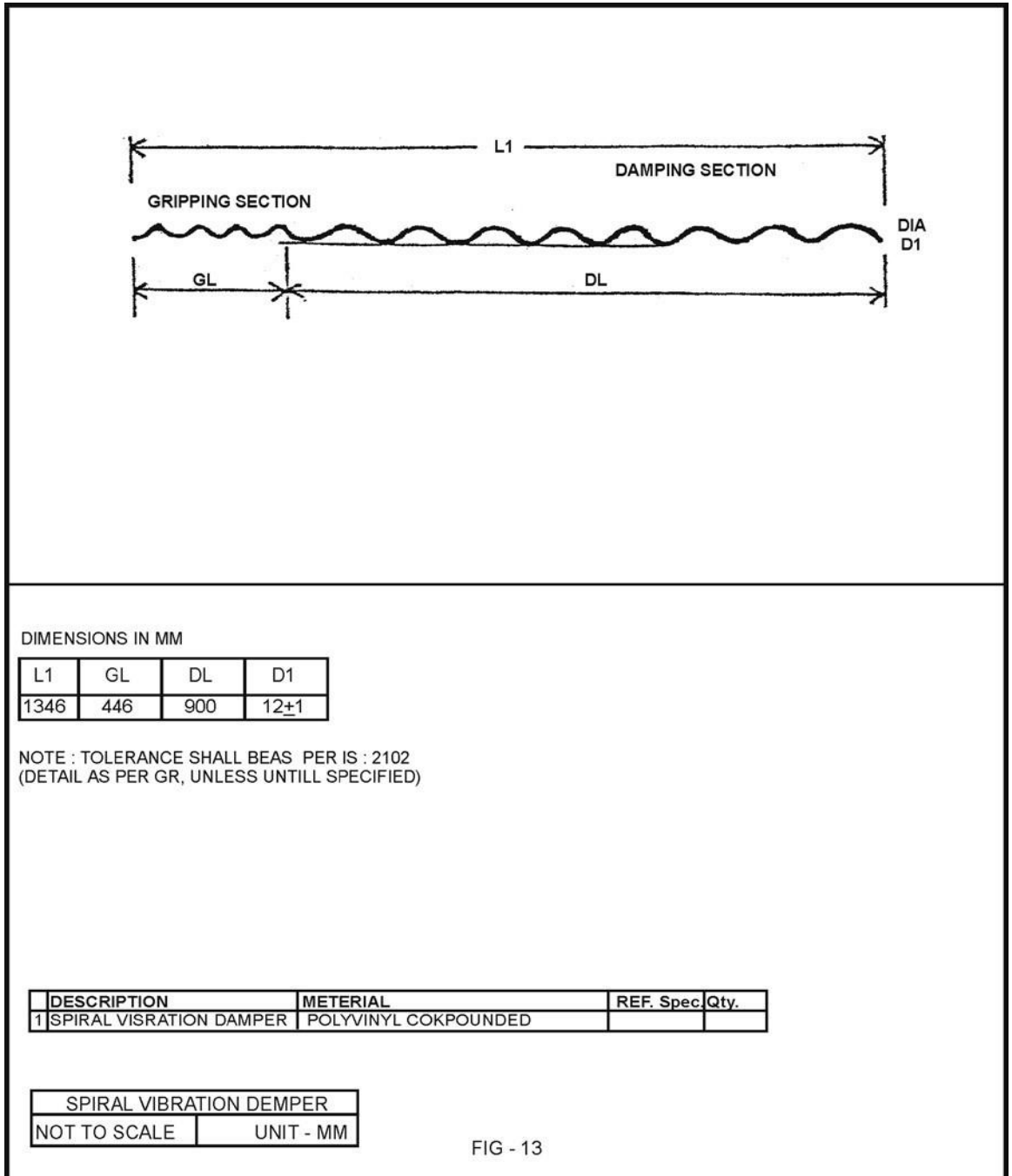

2. Universal Pole Clamp as per TSEC Type-I Design.

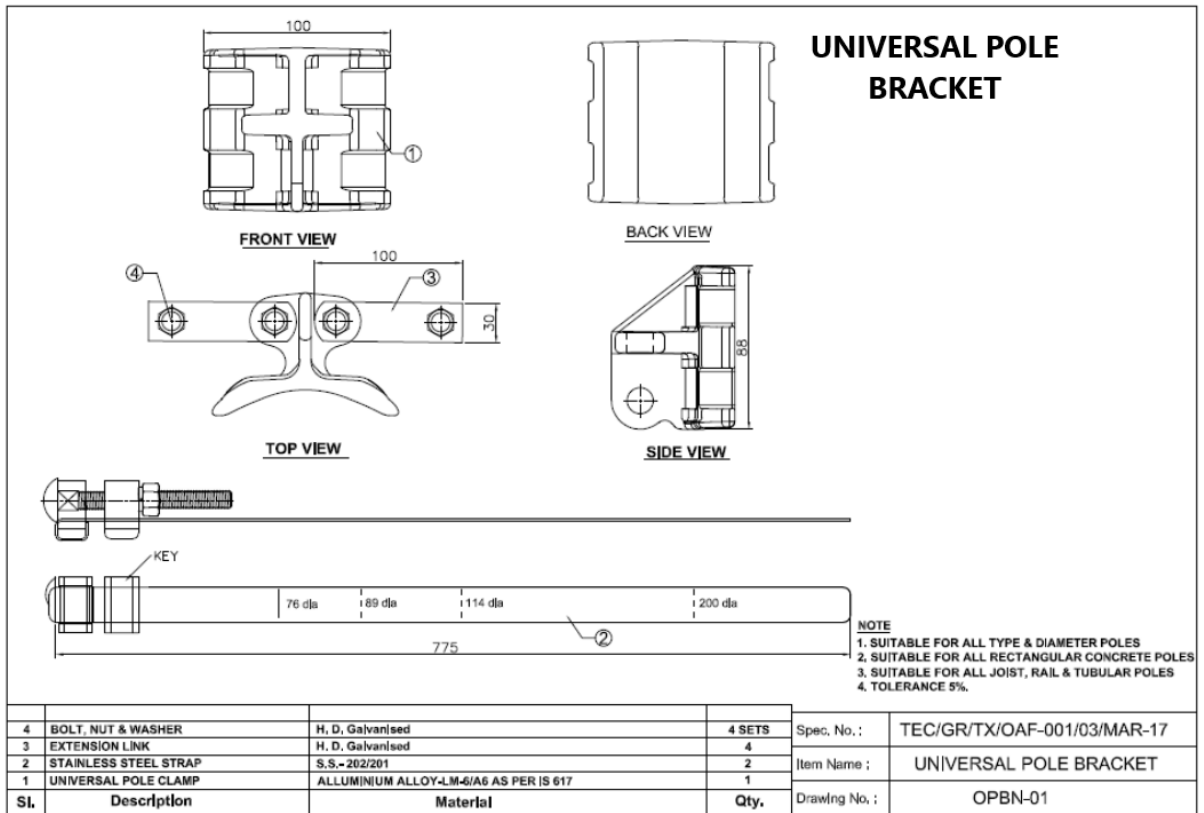

1.12 . SS 202 Strap 20mmx0.7mm of length 1.0 Mtr. as per TSEC Type-I Design.

PART – II

PRICE BID

1. PRICE:

(i) Bidders are required to quote their price(s) for goods offered indicating they are 'FIRM'

(ii) The prices quoted shall be FOR Destination only at the consignee's site/store inclusive of packing, forwarding, Freight & Insurance. In addition, the break-up of FOR Destination price shall be given as per schedule of Prices in Annexure-V of Section – III. The Bidders has to certify in the price bid that any implication of lower Tax and Input Tax Credit benefit as per anti-profiteering and other provisions under GST Laws, have been fully passed on to the Purchaser, while quoting the tender prices.

2. INSURANCE:

Insurance of materials covered by the Specification should normally be done by the Suppliers with their own Insurance Company unless otherwise stated. The responsibility of delivery of the materials at destination stores/site in good condition rests with the Supplier. Any claim with the Insurance Company or Transport agency arising due to loss or damage in transit has to be settled by the Supplier. The Supplier shall undertake free replacement of materials damaged or lost which will be reported by the Consignee within 30 days of receipt of the materials at Destination without awaiting for the settlement of their claims with the carriers and underwriters.

3. CERTIFICATE FOR EXEMPTION FROM GOODS AND SERVICES TAX:

Offers with exemption from Goods and Services Tax shall be accompanied with authenticated proof of such exemption. Authenticated proof for this clause shall mean Photostat copy of exemption certificates, attested by Gazetted Officers of State or Central Government.

4. PROPER FILLING UP OF THE PRICE SCHEDULE:

The Bidders should fill up the price schedule (Annexure-V of Section-III) properly and in full. The tender may be rejected if the schedule of price is submitted in incomplete form as per clause-34 (ix) of Section-II of the Specification.

5. NATURE OF PRICE INDICATED IN SPECIFICATION SHALL BE FINAL.

The nature of price indicated in the Clause-13, Section – I of PART –I of the Specification shall be final and binding.