



**ODISHA POWER TRANSMISSION CORPORATION LTD.
OFFICE OF THE ASST. GENERAL MANAGER: ELECT.
EHT (O&M) DIVISION: CHAINPAL
AT/PO: CHAINPAL COLONY, PIN-759104, and DIST: ANGUL (ODISHA)
Email: ehtm.div.chp@optcl.co.in**

TENDER CALL NOTICE NO. 03/13-14

**TENDER SPECIFICATION
FOR
FOR CONSTRUCTION OF RAIN WATER DRAINAGE SYSTEM OF MAIN
DRAIN, IN FRONT OF CONTROL ROOM OF 132/33KV GRID S/S, BOINDA.**

SALE OF TENDER SPECIFICATION:	DT. 28-02-2014
LAST DATE SALE OF TENDER SPECIFICATION:	DT. 27-03-2014
LAST DATE OF SUBMISSION OF TENDER:	DT. 28-03-2014
DATE OF OPPENING OF TENDER:	DT. 28-03-2014

COST OF TENDER PAPER: ` 2000/- + 5% VAT, i.e. ` 2100/-

Name of the tenderer: _____

Full postal address of the tenderer: _____

Contact telephone/ mobile no.: _____

E-mail address: _____

ASST. GENERAL MANAGER [ELECT.]

CONTENTS

1. SECTION -I: TENDER CALL NOTICE
2. SECTION -II: INSTRUCTION TO THE TENDERER
3. SECTION -III: GENERAL TERMS & CONDITIONS OF CONTRACT
4. SECTION -IV: TECHNICAL SPECIFICATION & PRICE BID
5. SECTION -V: DECLARATION BY THE BIDDER.

SECTION-1



ODISHA POWER TRANSMISSION CORPORATION LTD.
(A Government of ODISHA Under Taking)
OFFICE OF THE ASST. GENERAL MANAGER: ELECT.
EHT (O&M) DIVISION: CHAINPAL, AT/PO: CHAINPAL COLONY,
DIST: ANGUL (ODISHA), Pin-759104
Email-ehm.div.chp@optcl.co.in

TENDER CALL NOTICE NO. 03/ 2013-14

Sealed Tenders in duplicate are invited by the undersigned from intending Bidders having valid CIVIL Contractor License Class D and above, with PAN and VAT CC for construction of rain water drainage system of main drain, in front of control room of 132/33KV Grid S/S, Boinda, under EHT (O&M) Division, Chainpal as per details tender specification.

The tender specification & documents will be available in the office of the undersigned on written request and payment of ` 2100/- (Rupees Two Thousands, One hundred) only (Nonrefundable) towards cost of Tender paper in shape of cash/pay order/Demand draft drawn in favour of A.G.M., E.H.T. (O&M) DIVISION, OPTCL, CHAINPAL, payable at CHAINPAL on any working day from **Dt.28-02-2014 to Dt.27-03-2014 during office hour**. In case the Demand Draft made any other nationalized bank payable at any clearing branch at Talcher/Angul will be allowed, But the bidders have to deposit the collection fee (Bank transaction fee) along with the paper cost. The collection fee is Nonrefundable. Additional amount of Rs.100/-(One Hundred only) may be paid extra for postal delivery of the tender specification. The undersigned shall not be held responsible for any postal delay.

The Tender shall be received Up to 01.00 PM of dated 28.03.2014 & will be opened at 03.30 Hours of same day in the Office of the undersigned in the presence of the Bidders (or) their Authorized Representatives present if any. If any of the above date happens to be a holiday, the next working day will be the corresponding effective date. One Tender paper shall be issued to one Bidder. E.M.D @ 1% of the total quoted value should be deposited in shape of Demand Draft / Cash in favour of E.H.T. (O&M) Division, Chainpal & payable at "Andhra Bank", Chainpal Branch along with Self Attested Copy of PAN and Service Tax Registration Certificate failing which the tender will be liable for rejection.

The tenderer should be superscribed only the "Tender Call Notice No. & Date of Opening of the tender on the body of the Sealed Envelope". Bidder should not write their name or any other information on the body of the sealed envelope. Superscribing any other information on the body of the envelop, conditional tender, incomplete tender, Telegraphic / Fax / E-mail (etc.) Tenders & Tenders not accompanied with requisite amount of E.M.D. will be rejected. The authority reserves all rights to reject any, all or part of the Tender, alter/modify the requirement/ delete any part of the tender without assigning any reason thereof.

ASST. GENERAL MANAGER

SECTION-II

INSTRUCTIONS TO BIDDER

1. The contract shall be valid only for a period of 120 days from the date of opening of tender.
2. The authority reserves the right to award the contract among any responsive bidders against this tender.

Besides this, the authority reserves the right to accept or reject any or all tenders without assigning any reason thereof.

3. Clear Xerox copies of PAN & TAN, (VAT Registration & VAT clearance if applicable) certificate valid on the date of opening of tender should be submitted along with tenders, failing which the tender will be rejected. **Also the bidders have to submit all the documents as mentioned in Clause No.11 of SECTION-III.** The bidder or their authorized representatives should produce the original documents mentioned in Clause No.11 of SECTION-III for verification at the time of opening of the tender. Those who fail to produce the same and/or found not to be valid on the date of opening of tender or not matching with the Xerox copy submitted by the bidder; their tenders will be out rightly rejected. In case if only one bidder participate in the tender process, then undersigned may consider the case (*but not mandatory) & he will be given a chance to produce original documents in this office within one week from the date of opening of the tender.

4. In case of any dispute arising either in supply of construction material or any clause of agreement/ work order, the decision of the Unit Head, will be final and binding on the Bidder.

5. Tender with over writing, erased, illegible rates or rates not shown in figures and words in English will be liable for rejection. In case of discrepancy between words and figures noted against each item of the tender and between unit rates and total amount, the decision of the Competent Authority accepting the tender will be final and binding on the bidders. Total of item and grand total of whole tender be clearly written.

Correction in the tender, if un-avoidable, should be made by re-writing with dated initial of the bidder after scoring out wrong entries, clerical and arithmetical mistakes may result in the rejection of the tender.

6. The bidders shall sign on all pages of the tender document as a token of acceptance of all terms and conditions thereof and submit his quotations therein.

7. The schedule of prices should be filled up fully to indicate the break-up of the prices including taxes and duties. Incomplete submission of this schedule will make the tender liable for rejection.

8. Request from the bidder in respect of additions, alternations, modifications, corrections of either terms or conditions or rates after opening of the tender will not be considered.

9. All correspondence relating to the tender shall be made with Asst. General Manager (EL.),E.H.T. (O&M) Division, OPTCL, Chainpal.

N.B:-

- i) *All the materials required for work shall be of good quality relevant to concern IS. Engineer in charge shall ensure the quality of material supplied.*
- ii) *The Rate quoted by the bidder will be judged as per the recent OPWD code.*

SECTION-III

GENERAL TERMS & CONDITIONS OF CONTRACT

Sealed tenders are invited in duplicate from intending Bidders having valid CIVIL Contract License with PAN and VAT CC for construction RCC road in between 33kv & 132kv switch yard of 132/33kv Grid sub-station, Boinda under EHT (O&M) Division, Chainpal.

1. SUBMISSION & OPENING OF TENDER:-

Tender shall be submitted with other documents in duly sealed envelope super scribed on the body of envelope "Tender for construction of rain water drainage system of main drain, in front of control room of 132/33KV Grid S/S, Boinda, under EHT (O&M) Division, Chainpal". The bidder should write only Tender Specification No, the name of work and date of opening of the tender on the body of the sealed envelope. Bidder should not write their name or Agency name on the body of the sealed envelope which may make the offer liable for rejection.

2. RIGHT & AUTHORITY FOR REJECTION:- Tenders received after due date and time will be summarily rejected. The Asst. General Manager (Electrical), E.H.T. (O&M) Division, Chainpal reserves the right to reject any or all of the tenders without assigning any reason thereof.

3. VALIDITY OF OFFER:- The offer should be firm and valid for a period of at least 120 days from the date of opening of tenders. Unless the tender will be rejected.

4. EARNEST MONEY DEPOSIT:- The tender should be accompanied with 1% of the total quoted amount towards Earnest Money Deposit (EMD) in shape of Cash/ Bank Draft in favour of EHT (O&M) DIVISION, CHAINPAL payable at Andhra Bank, Chainpal, Talcher otherwise tender will be out rightly rejected. In case the D.D made any other nationalized bank payable at any clearing branch at Talcher/Angul will be allowed, But the bidders have to deposit the collection fee(Bank transaction fee) along with the EMD. The collection fee is Nonrefundable & It can't be taken into account of EMD deposit. The EMD of the unsuccessful bidders will be returned after finalization of tender. The EMD of the successful bidders will be returned only after the Security money deposited as per the clause No.(6) in Section (III). In case of successful bidder fails to execute the order satisfying all terms & conditions or also fails to commencement of work within stipulated date mentioned in the date of order, the Earnest Money Deposit will be forfeited. No interest will be paid on the EMD to any participator.

5. PRICE:- (a) The bidders are advised to quote their rate as per the price schedule attached at Annexure – II and should be inclusive of all duties, labour charges, royalty, VAT, Octroi and any other taxes if any. But service tax will be paid extra, if any as per rule. Statutory taxes, as applicable, to be deposited by employer, shall be deducted from the bills, as per rule.

(b) No claim shall be entertained against the department on account of any increase in price of materials during the course of execution of works or after tendering for this work.

6. SECURITY DEPOSIT:- The bidders whose offer qualifies for acceptance will be awarded work order for execution of the works and the bidder shall have to deposit security amount equal to 10% (ten percent) of contract value in shape of cash/bank draft drawn in favour of respective paying officer, of OPTCL, The security deposit shall remain valid till two months after the expiry of the guarantee period as stated under clause-10 of SECTION-III, and shall be released on receipt of application for this purpose. No Interest shall be paid to the bidder towards the security deposit so deposited by the Bidder. The security deposit shall be deposited with the paying officer of OPTCL prior to commencement of work. In case of Non fulfillment of contractual obligation by the supplier, the same so deposited shall be forfeited.

7. COMMENCEMENT & COMPLETION OF WORK:- The works awarded should commence within 15 days of the award of the contract and should be completed within 60 days. If the work could not be completed within scheduled date due to force majeure condition, then completion period may be extended on written request by the Bidder. If the work will not

commence & complete within the stipulated period, then the penalty should be imposed as per clause No.08 of SECTION-III.

8. PENALTY: - Penalty @ ½% (half per cent) per week up to a maximum of 5% of the total value of the work order will be imposed and recovered from dues admissible if the work will not completed within the specified date in SECTION –III, clause-7. However imposition of penalty clause is subject to force majeure condition.

9. TERMS OF PAYMENT: - 100% (one hundred percent) payment along with full taxes and duties (if any) shall be made after successful completion of the work in all respect and verification thereof by respective consignee and paying officer subject to availability of funds from Head Quarters office and against deposit of 10% security cum performance guarantee, otherwise the same will be deducted from the final bill which will be released after completion of Guarantee period.

10. GUARANTEE PERIOD: - The work done by the contractor as per contract specification should be guaranteed for satisfactory operation and against any defects, in materials & the workmanship for a period of 12 months from the date of completion of the work and handing over to consignee. The above guarantee certificate shall be furnished in triplicate to the undersigned for approval. Any defects noticed during the period shall be rectified by the contractors at its own cost, without any financial burden to OPTCL.

11. DOCUMENTS:- The following Xerox copy should be submitted with the tender paper & the same will be verified with original documents at the time of opening of tender.

i) **Civil Contract License (D class & above)**

ii) Service Tax Registration Certificate from the Central Excise Deptt.

iii) Valid PAN/ TIN.

iv) VAT Regd. & VAT CC

v) Experience Certificate (optional)

12. ADDITION OR DELETION OF CONTRACT:- The Contract may be altered in quantum as per exigencies of work. The bidder shall accordingly provide services as may be required by the Officer- in -Charge on being given a notice of 15 days.

13. ARBITRATION:- In the event of any dispute arising out his contract, the same shall be referred for arbitration to the Director (HRD) OPTCL, Bhubaneswar or any arbitrator appointed by the Chairman- Cum- Managing Director, OPTCL after due notice of claim and such appointment and the award of the arbitrator shall be final and binding arbitration and conciliation Act. 1996 shall apply. The venue of arbitration will be Bhubaneswar.

14. CONSIGNEE:- The Manager, TL S/D Boinda is the consignee for the contract..

15. PAYING OFFICER:- The AGM, EHT(O&M) Division, Chainpal is the paying Officer for contract.

16. JURISDICTION OF COURT:- In case of any dispute arising between the ordering authority and the firm/supplier, either party can take shelter in the court of law at Talcher in the State of Odisha.

17. SAFETY PRACTICE:- The Bidder must be follow the OPTCL safety Rule while performing the work. The workmen must be provided personal protective equipment(PPE) by the contractor while performing the works .No deviation will be allowed and the consignee has got any power to stop the work at any time on the breach of safety practice .

The authority reserve the right to reject any or all tenderer or award the contract among any responsive bidders against the Tender without assigning any reason thereof.

SECTION-IV
TECHNICAL SPECIFICATION (WITH DRAWING) & PRICE SCHEDULE

TECHNICAL SPECIFICATION:-

The Scope of work: - The scope of works must cover the followings & as per Drawing.

- i) 8mm diameter steel shall be used as mention in the drawing. Steel having IS-1786 shall be used of any reputed brand which are established, reliable, indigenous and primary producer of steel having integrated steel plant (ISP), using iron ore as basic raw materials as per ministry of steels guideline. No re rolled steel shall be permitted in work.
- ii) 53 grade cement shall be used of any reputed manufacturers of cement inside the state.
- iii) Pond watering shall be provided for RCC work as per the instruction of site in-charge. The contractor has to arrange adequate supply of clean water required for the work whenever necessary at his/her own cost.
- iv) The successful tenderer shall make his own arrangement for all materials and T&Ps such as concrete mixture, vibrator etc.
- v) The coated rate for the work will deem to include all incidental items which may necessary for construction of benchmarks, level pillars, profiles, benching levels of the ground etc where required. No extra payment or claim will be admissible on these ground.
- vi) Cleaning of debris where necessary shall be considered as incidental to the work and shall be the responsibility contractors to clean it.

DRAWINGS:-

DRAWING FOR CONSTRUCTION OF RAIN WATER DRAINAGE SYSTEM OF MAIN DRAIN, IN FRONT OF CONTROL ROOM OF 132/33KV GRID S/S, BOINDA.

NOTE:

1. CONCRETE MIX 1:1.5:3
2. CLEAR COVER FOR WALL 25MM
3. GRADE OF STEEL - Fe 500D
4. LAP LENGTH 47DIA.

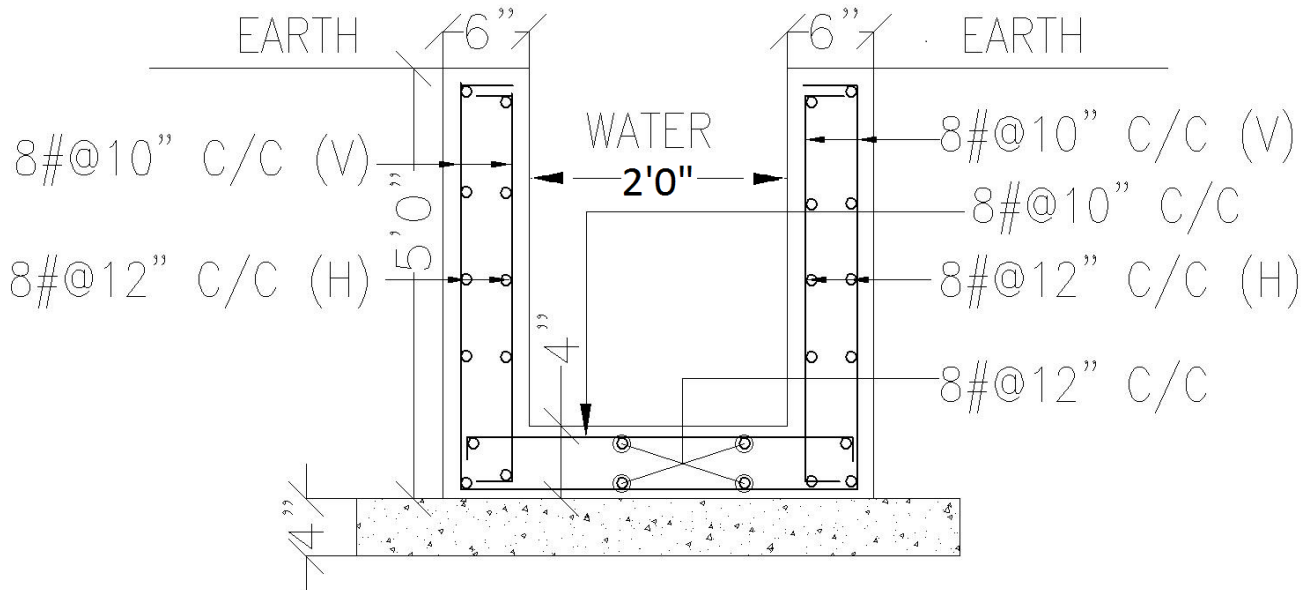

DRAIN C/s. REINFORCEMENT DETAIL.

PRICE SCHEDULE
PRICE SCHEDULE FOR CONSTRUCTION OF RAIN WATER DRAINAGE SYSTEM OF MAIN DRAIN, IN FRONT OF CONTROL ROOM OF 132/33KV GRID S/S, BOINDA.

Sl. No	Description of Work	Qty	Unit	Rate/ Unit in Rs	Total Amount in Rs.
1	Earth work in excavation (E.W.E) : Excavation of damaged road (in hard soil) with all leads and lift including dressing of sides and leveling the bed of the foundation (Road) including cost of all labour and T&P required for the work etc. complete and disposing excavated materials away from the working area as directed by Engineer in charge .	84.9	Cum.		
2	P.C.C.(1:4:8) with 40 mm size crusher broken hard granite metal, cleaned washed good quality river sand and cement (53 grade) with cost of all labour, material, T&P etc. including watering.	07	Cum.		
3	Supply of all material for Centering and Shuttering with good quality wood and planks with cost of all labour, material, T&P. etc. complete.	278.7	Sq. Mtr.		
4	Supplying, fitting and placing of 8 mm size TMT bar conforming to IS 1786 Fe500D for Reinforcement including the cost of steel and binding wire for cutting, bending, binding and placing in position, as per the drawing and technical specification with supply of all T&P and labour as per the instruction of the Engineer in charge.	2753	Mtrs.		
5	R.C.C. (1:1.5:3) with 20 mm and downgraded size of HBG with clean river sand and cement (53 grade) with cost of all labour, material, T&P etc. and pond watering.	25.47	Cum.		
	GRAND TOTAL (1+2+3+4+5) In Rs.				

In words: (.....
.....) Only

Signature of the Bidder with date
Page: 9 of 11

SECTION-V

DECLARATION BY THE BIDDER

1. Name of the bidder with
Detailed postal address with
Contact Number.
2. Earnest money deposited vide Cash receipt/ Bank Draft
No.....Dated.....
Amount in Rs.....(Rupees.....)
only.
3. Xerox copy of PAN No: Furnished/ not furnished
4. CIVIL Contract License Furnished/ not furnished
5. Xerox copy of VAT Registration certificate: Furnished/ not furnished
6. Xerox copy of VAT clearance certificate: Furnished/ not furnished
7. Xerox copy of Service Tax Registration No. Furnished/ not furnished
8. Agreed to furnish & accept Contract Security deposit clause: Yes/ No.
9. Agreed to accept payment terms as per Tender Specification. Yes/ No.
10. Agreed to adhere delivery period as per the contract: Yes/ No.
11. Agreed to accept penalty clause as per the tender: Yes/ No.
12. Attach past experience certificate for the similar jobs
in OSEB/ GRIDCO or any other agencies along with the
copy of valid HT/ HV license. : Yes/ No.
13. Agreed to keep validity of the offer for one year from the
Date of tender opening without any variations in tender clause: Yes/ No.
14. Agreed to obtain labour contract license on event
of work order from the competent authority (if required): Yes/ No.

Date:
Place:

Signature of the Bidder
with seal

THE BIDDERS ARE REQUIRED TO FURNISH THE FOLLOWING DETAILS AS PER THE FORMAT GIVEN BELOW WHICH IS A MANDATORY REQUIREMENT FOR EVALUATION OF BIDS

SL NO	DETAILS	TO BE FILLED BY THE BIDDER
1	BIDDER'S NAME	
2	BIDDER'S SITE NAME (NAME OF THE PLACE)	
3	ADDRESS	
4	CITY	
5	STATE	
6	COUNTRY	
7	PIN CODE	
8	PHONE NUMBER	
9	FAX NUMBER	
10	CST REGISTRATION NUMBER	
11	VAT REGISTRATION NUMBER	
12	SERVICE TAX REGISTRATION NUMBER	
13	PAN NUMBER	
14	TAN NUMBER	
15	CONTACT PERSON'S NAME	
16	POSITION/DEPARTMENT OF CONTACT PERSON	
17	CONTACT PERSON'S E-MAIL ID	
18	CONTACT PERSON'S PHONE NO.AND MOBILE NO.	
19	CONTACT PERSON'S FAX NUMBER	

Signature of Bidder with Seal